



V4 Non-LMI System User Manual

Updated: February 4, 2021



Contents

Cranesmart V4 Non-LMI System	1
Warranty	4
Important Safety Information	5
1. The User Interface	6
1.1. The Startup Screens	6
1.2. The Home Screen.....	6
1.3. The Menu Screens	9
1.4. The Value Entry Screen	11
2. Normal Operation	13
2.1. Load Indication	13
Load Limits.....	15
Load Tare.....	17
2.2. Anti-2-Block Indication	19
2.3. Angle Indication	20
Angle Limits.....	20
2.4. Level Indication	22
Level Limits	23
2.5. Wind Speed Indication.....	24
2.6. Adding a Spare Transducer	26
2.7. Using the USB Functions (Data Logging and Upgrading the System Firmware).....	29
Data Logging.....	29
Viewing the Data Logs.....	31
Upgrading the System Firmware	35
3. The Configuration Menu	37
3.1. Winch.....	38
3.2. POL (Parts of Line)	38
4. The Settings Menu	39
4.1. Limits	39
4.2. Calibration	40

Load Calibration.....	41
Angle Calibration.....	43
Level Calibration	45
Boom Length Calibration.....	47
Powerline Calibration.....	48
4.3. Panel	48
Relay.....	49
Parameters	50
Save / Restore.....	50
Audio.....	51
USB	51
Logs	52
4.4. Enable / Disable / Add	52
4.5. Units.....	53
4.6. Locks.....	54
5. The Information Menu.....	55
5.1. About.....	56
5.2. Limits	57
5.3. Transducer Stats – Radio.....	58
5.4. Transducers Stats – Info.....	58
5.5. Panel	59
6. The Permission Menu.....	60
6.1 System Screen Flowchart.....	61
6.2. Entering the Permission Level Code.....	62
6.3. Supervisor Access Screens.....	63
8. The LCD Brightness and Audio Menu	68
8. The Language Menu.....	69
9. The Time and Date Menu	70
10. Troubleshooting	71
10.1. Alarm and Warning Screens.....	71
10.2. Replacing a Transducer Battery	72
10.3. Replacing a Load Cell Battery.....	73

11. Appendix	75
11.1. Installation Instructions.....	75
11.2. Load Cell Link Installation A	76
11.3. Load Cell Link Installation B	77
11.4. Load Cell Link Installation C	78
11.5. Load Cell Link Installation D.....	79
11.6. Load Cell Link Installation E.....	80
11.7. Load Cell Link Installation F.....	81
11.8. Radio Linerider Installation.....	82
11.9. Hydraulic Boom Linerider Installation	83
11.10.Lattice Boom Linerider Installation	84
11.11.Installing the Wire Rope Through the Linerider	86
11.12.Load Pin Installation.....	87
11.13.Anti-2-Block Installation	90
11.14.Boom Angle Transducer Installation.....	92
11.15.Windspeed Transducer Installation	93
11.16.Level Transducer Installation Type A	94
11.17.Level Transducer Installation Type B.....	95
11.18.Powerline Proximity Sensor Installation.....	96
11.19.Display Panel Installation	97
11.20.Alarm Shutoffs (White Wire)	99
11.20.Display Panel Wiring Diagram.....	101
11.21.Power Converters.....	102
11.22.Hazardous Area Options	102
11.23.Integration Module (Digital) Installation	102
11.24.IMD Wiring Diagram.....	105
11.25.Antenna Installation	106
11.26.Shut-Off Bypass Plug.....	107
11.27.ASME B30.14 Excerpt (Power Lines)	109
11.28.Occupational Safety and Health Administration 1926.1408 Excerpt (Power Lines).....	110

Warranty

Cranesmart Systems warrants to the purchaser of each new Cranesmart System that any part thereof which proves to be defective in material or workmanship within two (2) years from date of delivery will be repaired or replaced at no charge if the system is returned to us in Edmonton, Alberta with all freight charges prepaid. If a performance problem should occur, contact our office/manufacturing facility in Edmonton, Alberta at (888) 562-3222 or (780) 437-2986 (Address: 4908 97 St NW, Edmonton, AB T6E 5S1).

This warranty does not cover defects resulting from accident, alteration, improper use, or failure of the purchaser to follow normal operating procedures as outlined in this instruction manual.

PLEASE NOTE:

- Changes or modifications not expressly approved by the party responsible for compliance could void the user's authority to operate the equipment.
- This device complies with part 15 of FCC rules, and Industry Canada license-exempt RSS standard(s). Operation is subject to the following two conditions: (1) this device may not cause interference, and (2) this device must accept any interference, including interference that may cause undesired operation of the device.
- The display panel is a category 2 item as per IC and FCC radio certification
- This warranty is in lieu of any warranty or merchantability and of all other warranties, expressed or implied, all of which are hereby excluded.
- The display panel operates at an input range of 12-24 VDC at 1 A.
- The wireless transducers operate at 3.6 VDC at 30mA (battery).
- All Cranesmart devices are FCC compliant and are labeled clearly as such.
- All Cranesmart devices have an IP rating: 68, and an operable temperature range of: -40°C to +60°C (-40°F to 140°F).



- **WARNING:** OPENING THE DISPLAY PANEL VOIDS THE WARRANTY.



- **WARNING:** NO COMPONENTS OF THE SYSTEM ARE TO BE SUBMERGED IN WATER.



- **WARNING:** DO NOT PRESSURE-WASH CRANESMART COMPONENTS. DIRECT APPLICATION OF HIGH-PRESSURE WATER CAN BREAK SEALS AND LEAD TO MOISTURE DAMAGE.



- **WARNING:** POTENTIAL ELECTROSTATIC CHARGING HAZARD: USE A DAMP CLOTH ONLY TO WIPE CLEAN THE EXTERIORS OF COMPONENTS.

Cranesmart Systems shall in no event be liable for any special, indirect, or consequential damages whatsoever and neither assumes nor authorises any person to assume for it any other obligation or liability.

Important Safety Information

All of Cranesmart Systems' load cells and support hardware have been designed and tested to have a minimum 5 to 1 safety factor and to meet or exceed the guidelines, standards and certification requirements set forth by more than 30 legislative bodies worldwide including API, ABS, DNV, ASME and OSHA.

All Cranesmart load cells and support hardware are to be considered 'Critical Path' components. Loads imposed on these components should never exceed the maximum rated capacity shown on the load cell. The rated capacity applies only to uniform direct tension loading (straight-line pull). Off-axis loading, bending, side loading, two-blocking and shock loads should be avoided. Damages caused by such situations are not covered by the Cranesmart Systems warranty.

Inspection for damage, deterioration, cracks and corrosion on all load bearing components should be conducted pre-use, weekly, monthly, quarterly or annually, depending upon crane usage. Load bearing components showing damage, deterioration, cracks or corrosion should be removed from service. If the crane is two-blocked or side loaded, the load cell and links should be visually inspected immediately. Continued use of damaged components may result in catastrophic failure and personal injury.

Unless authorized by the factory in writing, modifications such as cutting, welding or permanently attaching other material to any load cell, pin, link or part thereof will void the warranty. Do not repair, alter, rework, or reshape any load bearing component by welding, heating, grinding or bending. Do not engrave or stamp marking into the steel body of the load cell as this may affect the integrity of the load cell, will void the warranty, and may result in a costly replacement of the steel body.

Regular Inspections

We recommend that all load components regularly undergo routine visual inspection as noted above. We also recommend that a qualified inspector, using industry standard techniques such as Ultrasonic Testing and/or Dye Penetrate Testing, annually inspect the load components. These tests are to be performed in conjunction with the inspection frequencies and guidelines as mandated by the applicable regulatory bodies.

NOTE: Do not disassemble the load cell by removing the plastic covers during testing. Disassembly will require the cell to be returned to the factory for calibration and testing.

If any issues arise, contact the Cranesmart Systems main office @ 780-437-2986 and ask for the service department. Please have the component serial number(s) readily available.

NOTE: The Cranesmart System is designed for and intended to be used as an operator safety aid for cranes, pipelayers and similar load lifting machinery. Operational parameters such as: load weight, boom angle, anti-2-block status, level indication, (and others) are monitored by the system and displayed clearly for the operator in order to make working conditions safer, and operations more accurate and efficient. This manual has been written in the effort to explain the most pertinent details of this system and its use.

1. The User Interface

The new Cranesmart Non-LMI 4 System utilizes a large full color touchscreen display panel, which is described generally, in this section. All information, parameters, menus and alarms are displayed and accessible directly via the touchscreen, with no need to use the hardware buttons located beneath the display. These buttons will be integrated in later versions of the system for extended functionality.

NOTE: The touchscreen does not respond to increasing pressure on its surface - to make a selection, use only light contact directly overtop the desired button to avoid potentially damaging the screen.

1.1. The Startup Screens

Illustrated below are the Startup Screens, which are displayed immediately upon powering the system. First is a picture of the components, followed by a certification screen, then a quick system diagnostics checklist. Once the system is fully initialized, the main user interface will appear.

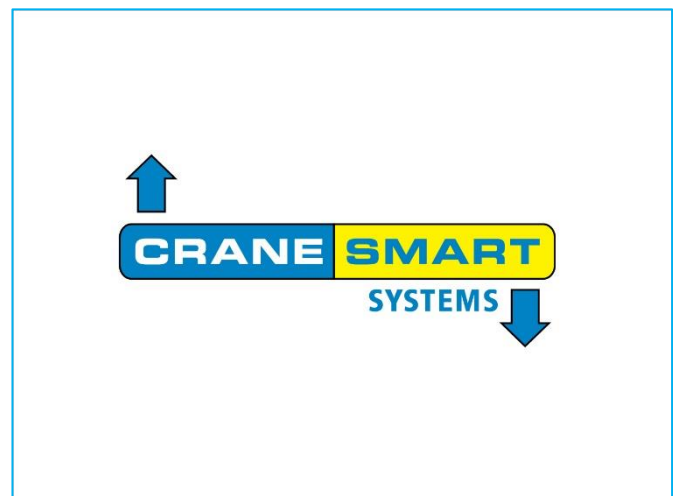
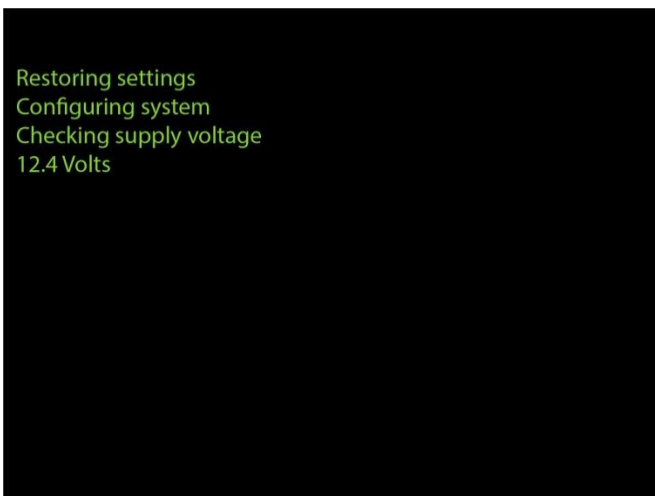

1.2. The Home Screen

Shown below is the Home Screen, which is the main display for normal operation. The system updates in real time, all the most important parameters of the system and displays them here for the operator. The elements of the display are labeled and explained on the following page.

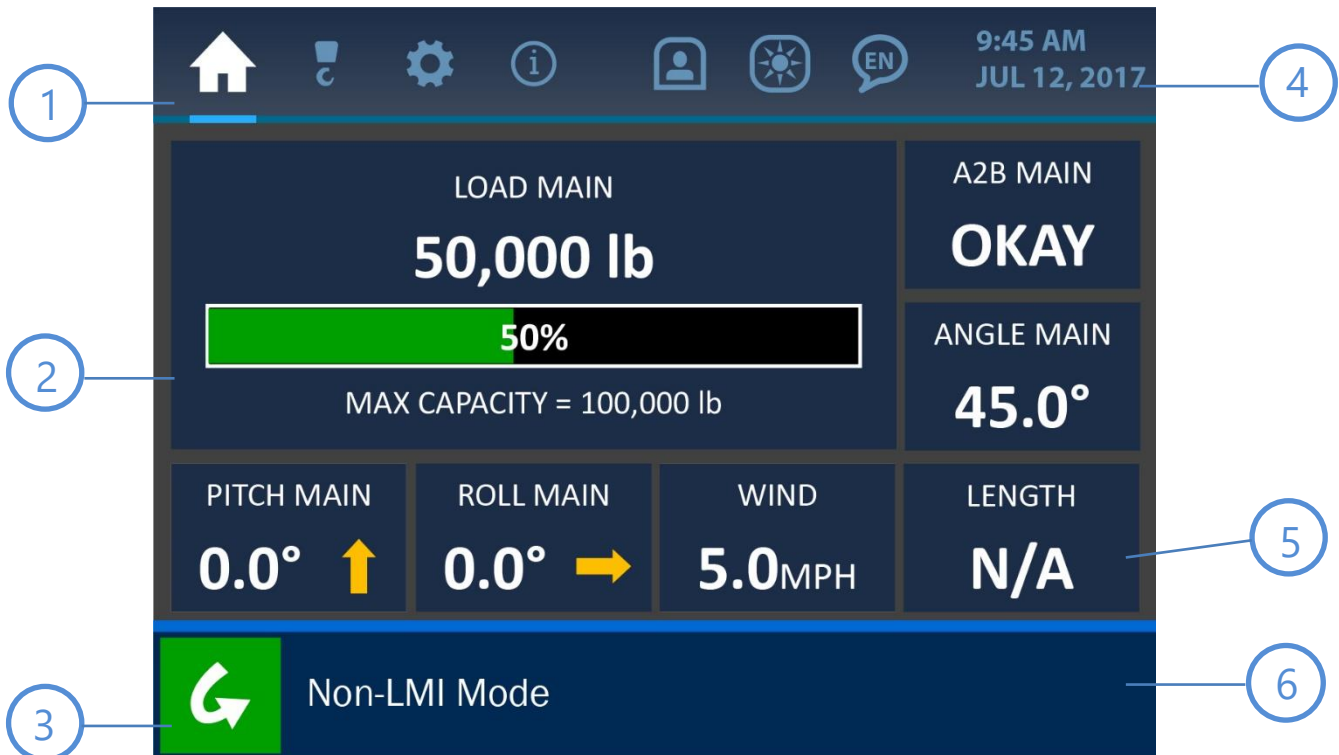

1 Menu Tabs

Across the top of the display are the Menu Tabs for accessing the main functions of the system. From left to right, the tabs represent these menus: Home / Configurations / Settings / Information / Permission Level / Brightness and Audio / Language. These tabs are visible and accessible at all times.

2 Load Display

The primary section of the Home Screen shows the load information. Here, the current load on the hook is displayed in the chosen units of measurement, as well as the (programmed) maximum load allowed for the system. The current load as compared to the maximum is also displayed visually as a bar graph and percentage.

3

Bypass Button

Pressing this button will shut off any audible alarm and dismiss any warning message for a period of 30 seconds. The display will show this time interval counting down, until the timer runs out completely and the alarm is reactivated. A more detailed description of the alarms and their displays can be found in the *Troubleshooting* section of this manual.

4

Clock

The upper right area of the screen shows the system clock. The time of day as well as the month and year are displayed clearly for the operator. This information can be changed by pressing the screen directly over the clock display, which will open the Time and Date Screen. See *The Time and Date Menu* section of this manual for more information.

5

Secondary Parameter Tiles

Beneath the load display are other important parameters being monitored by the system: A2B status, boom angle and machine pitch / roll. Pressing the area of the screen overtop each parameter shown will open an associated menu for that parameter, where certain values can be changed or displayed.

6

Alarm and Notification Bar

The lower section of the screen shows the Alarm and Notification Bar. As shown in the screenshot, the system pictured is experiencing no alarms and shows the default notification, 'Non-LMI Mode'. In case of an alarm, an associated message would be displayed in this area, with color changes to indicate the problem visually. Further description of the alarms and their displays can be found in the *Troubleshooting* section of this manual.

1.3. The Menu Screens

Shown below is an example of a typical Menu Screen. Its various components are described on the following page.



1

Banner Buttons

Every listed item on a menu screen is shown overtop a blue Banner Button. If the item is changeable or linked to a further submenu, pressing anywhere on the banner button will advance the display to show more associated options.

2**Message Tabs**

Across the bottom of the menu screens are the various message tabs that display different kinds of information to the operator. The tabs in order from left to right are: Alarms / Warnings / Notifications.

3**Page Indicator**

This symbol indicates that more menu items are available but cannot all be displayed simultaneously. Pressing directly overtop the page arrows will increment or decrement the menu accordingly.

4**Back Button**

Pressing this button will reopen the previously viewed screen, making menu navigation faster and easier.

1.4. The Value Entry Screen

Shown below is an example of a typical Value Entry Screen. This is the format used for any instance where a numerical parameter must be set or changed. The various components of this screen are labeled and described below.

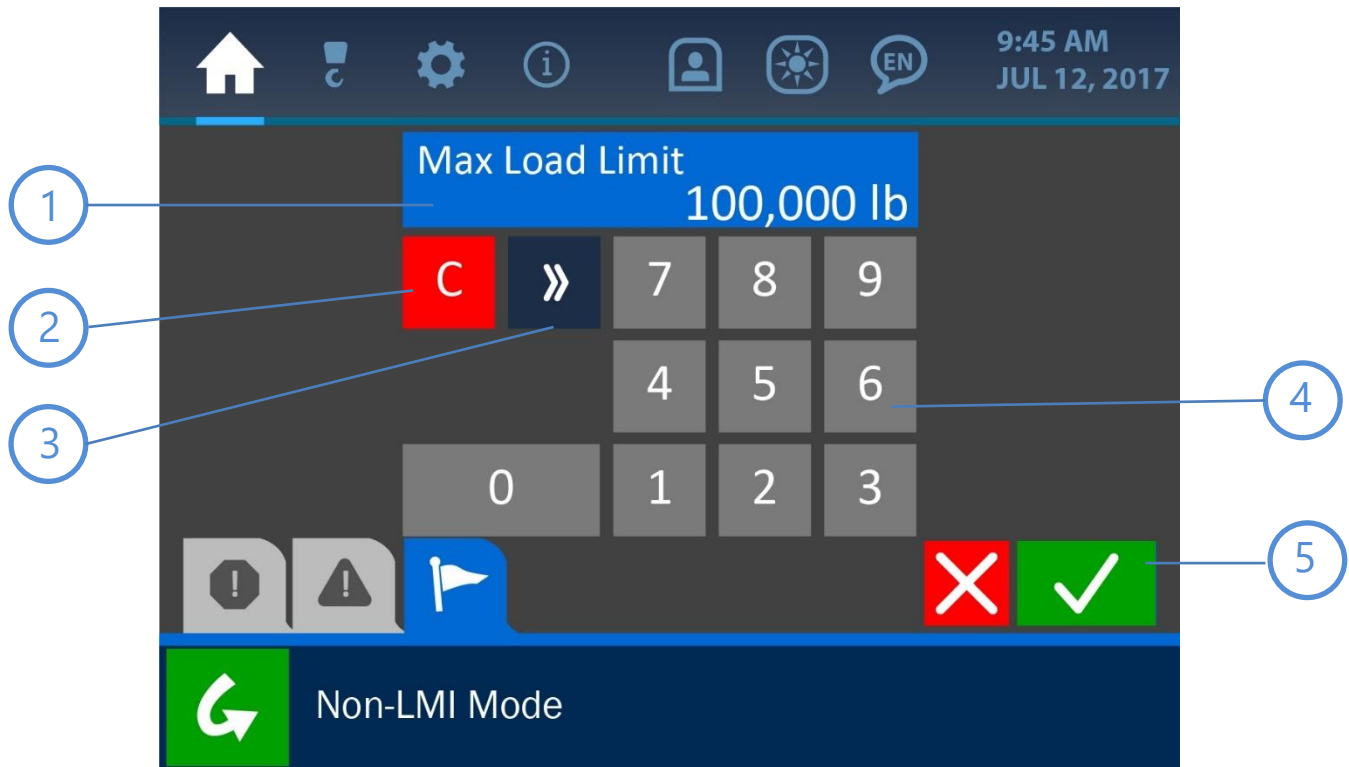

1

Value Window

The value in question will be displayed in this area, showing updates as they are made by pressing the keypad buttons.

2

Clear Button

Pressing this button will clear the Value Window, setting the value to 0.

3

Delete Button

Pressing the Delete Button will delete the first digit (from the left) displayed in the Value Window.

4

Keypad

Press the keypad buttons to set the new value to be used, as displayed in the Value Window.

5

Cancel and Accept Buttons

Pressing the (red) Cancel Button will nullify any changes made on this screen and open the previous page displayed. The (green) Accept Button will confirm and save any changes made and open the previously displayed page.

2. Normal Operation

The Cranesmart Non-LMI 4 interface was designed to present the user with all the most important, real-time information regarding the machine in use, for the safest and easiest possible operation. This section of the manual explains each parameter on the Home Screen and other screens used during normal operation, how to view and change important settings, and the ways the system indicates potential danger.

NOTE: See 'The User Interface' section for explanations of the screen formats and common functions used throughout the system.

2.1. Load Indication

Shown below is the Home Screen, with the Load Indication Tile emphasized.

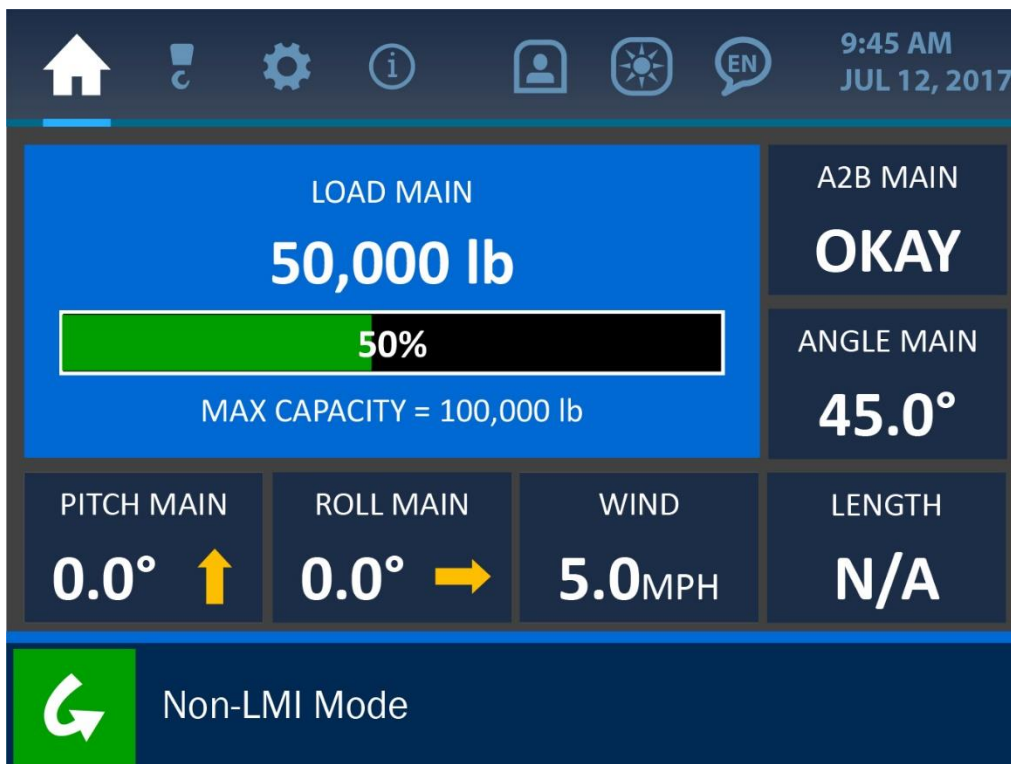

As shown in the previous screenshot, and the detail image below, the load is indicated by several factors at any given time. The current load on the hook is shown, as well as a bar graph and percentage indicating how close the current load is to the maximum capacity of the machine. This max load limit is set by a supervisor, and is shown below the bar graph as 'MAX CAPACITY'.



Pressing anywhere directly overtop the Load Indication Tile will open the Load Menu, as shown below. This menu offers the following options for the load: Limits, and Tare. These options are described on the following pages.

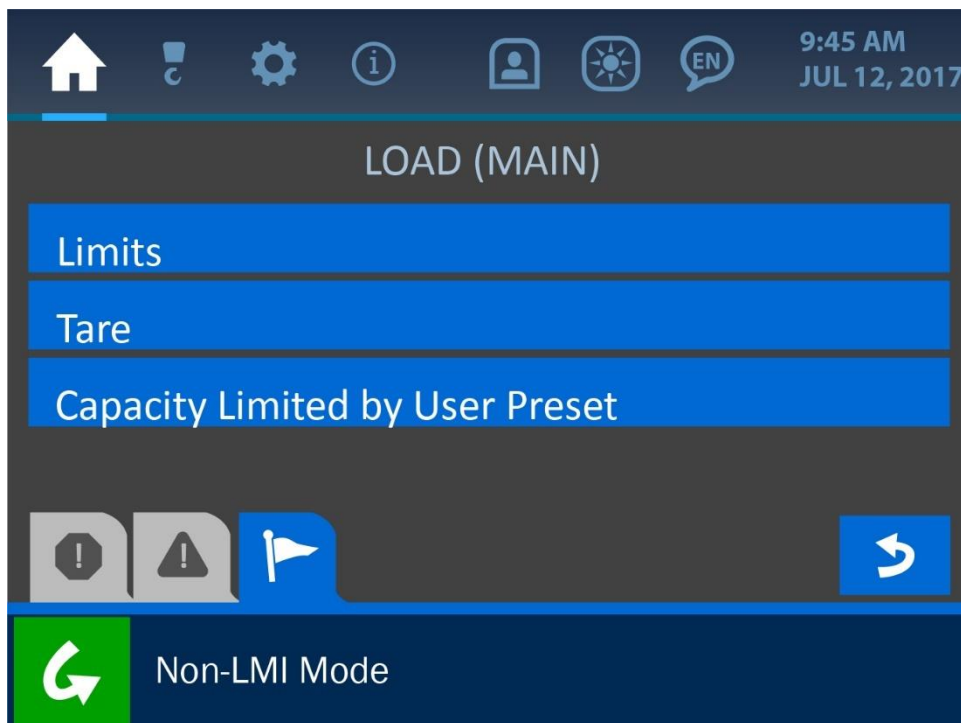

Load Limits



The Load Limits Menu displays the current settings for the following parameters:

Maximum: the current maximum load allowed before the system displays a load alarm condition

Minimum: the current minimum load value recognized by the system for proper display

Derate: this value indicates the capacity of the load chart that the system is set to recognize. If for example, the Derate value is set to 100%, the entire load chart is used at full capacity. If the Derate value were to be set at 50%, the machine would be enabled to function at only half of its actual capacity before the system shows an alarm state.

To edit any of the load parameter values, simply press the screen directly overtop the option to be changed to open the Value Entry Screen for that respective option.

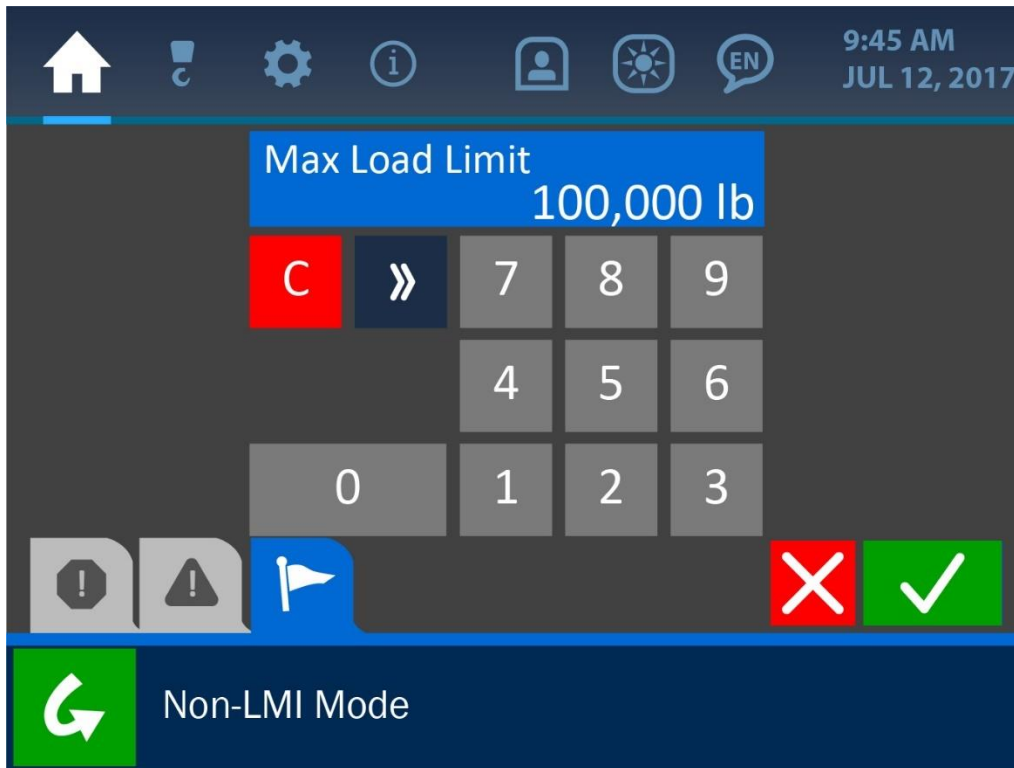

Once the Value Entry Screen is opened, use the keypad to enter the desired value for the parameter, and press the (green) Accept Button to save the change.

NOTE: See 'The User Interface' section of this manual for more information on the Value Entry Screen.

Load Tare

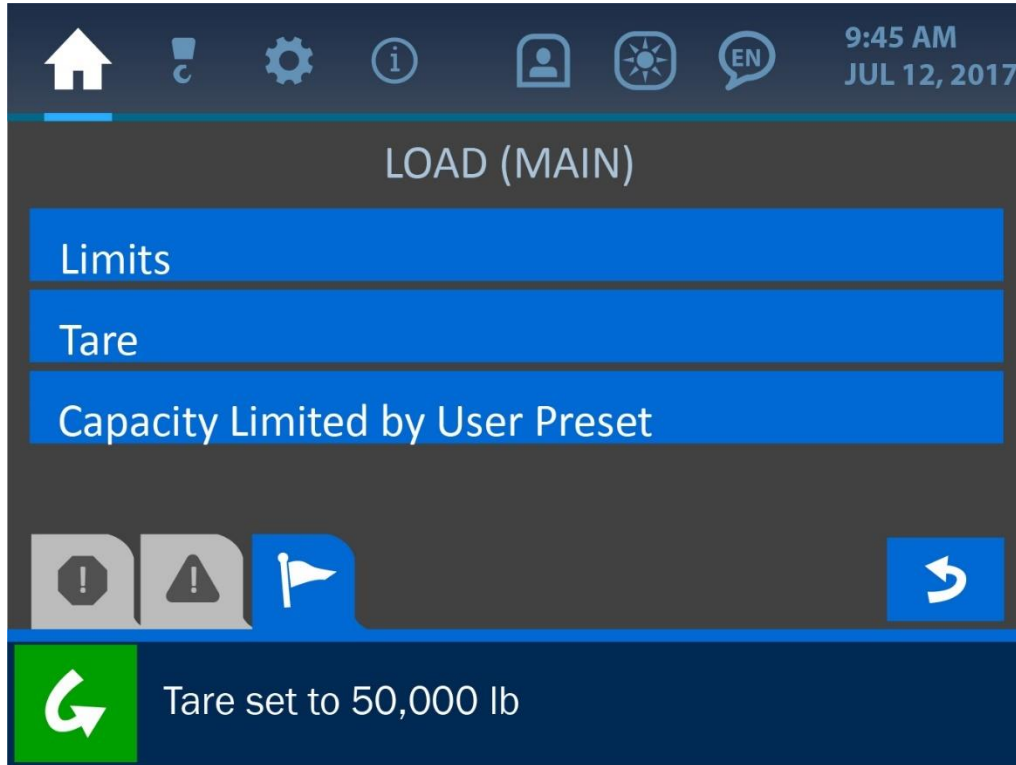

The Load Tare option enables an operator to set the current weight on the hook to zero. To do this, simply press the Tare Banner Button in the Load Menu. For the example of this screenshot, the system shown is displaying in the Notification Bar (along the bottom of the screen) that the current load of 23,000 lb has been set to zero. This is further indicated by the following screenshot of the modified Home Screen – the current load shows 0 lb and the 'T' symbol indicates that this zero-load is the result of the tare operation.

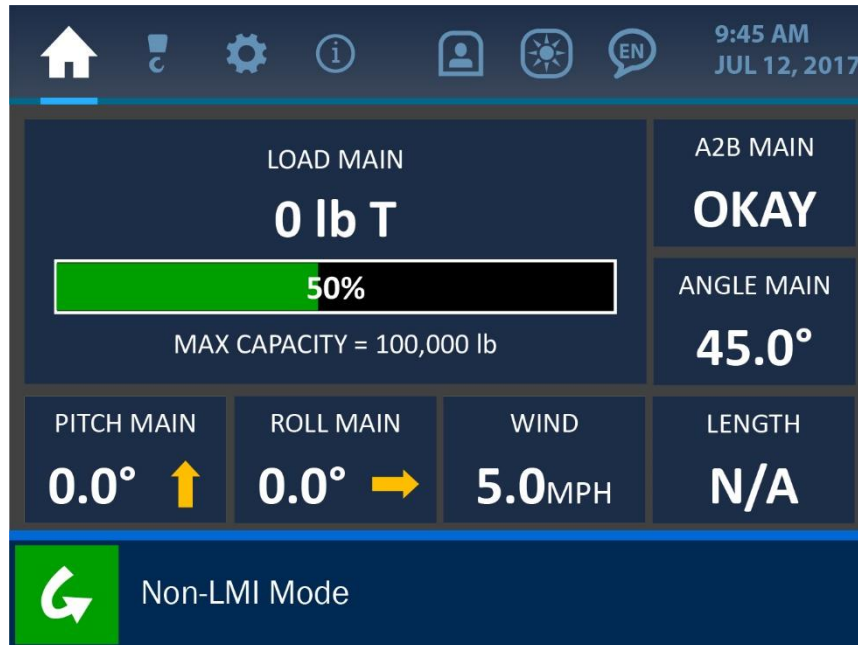

To clear the tare set point, simply re-enter the Load Menu, and press the Tare Banner Button again. The Notification Bar will indicate that the tare has been cleared, as shown in the screenshot below.

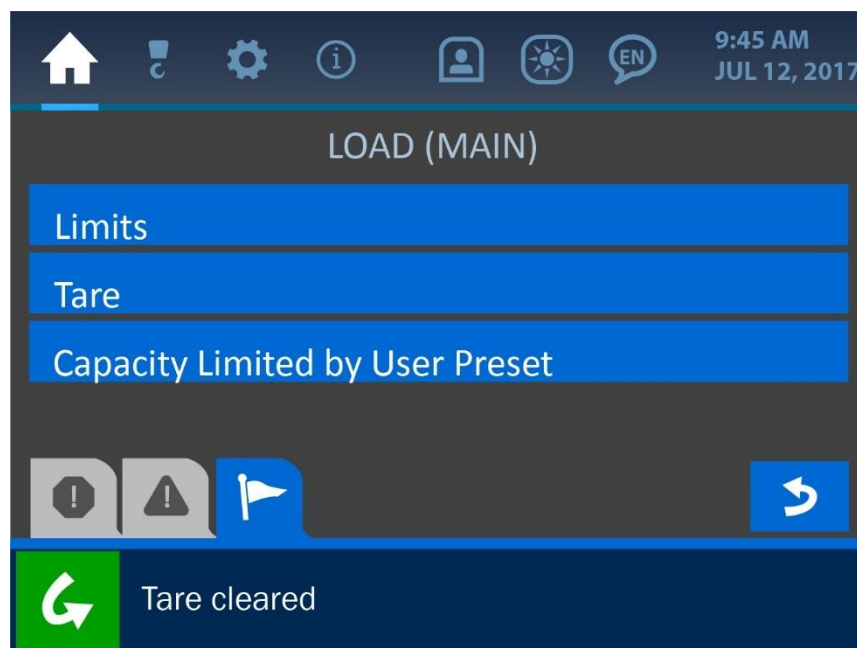

2.2. Anti-2-Block Indication

Shown below is the Home Screen, with the Anti-2-Block Indication Tile emphasized.

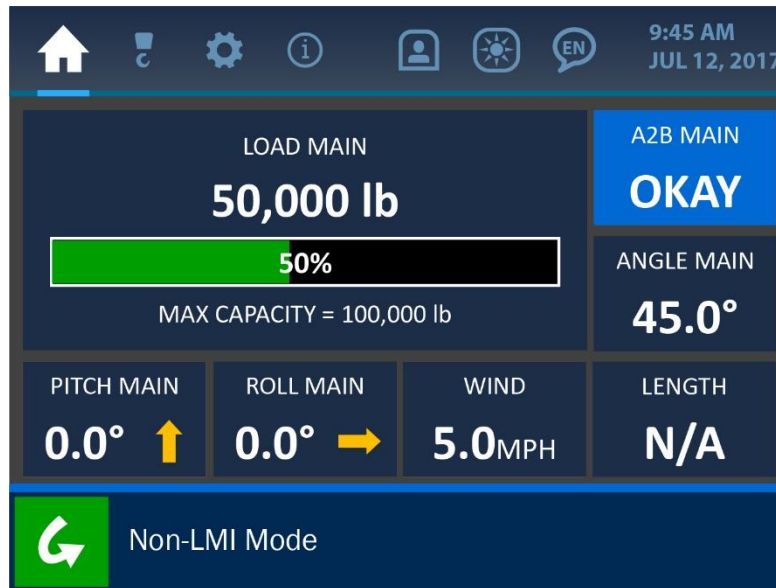

As illustrated above, the A2B status reads simply 'OKAY', indicating the transducer is sensing the load of the counterweight and is operating normally. In case of a 2-block situation, the A2B status will display this state as shown below. An associated alarm message will also display in the Alarm and Notification Bar along the bottom of the screen.



NOTE: See the 'Troubleshooting' section of this manual for more information on various alarm states and displays.

2.3. Angle Indication

Shown below is the Home Screen, with the Angle Indication Tile emphasized.

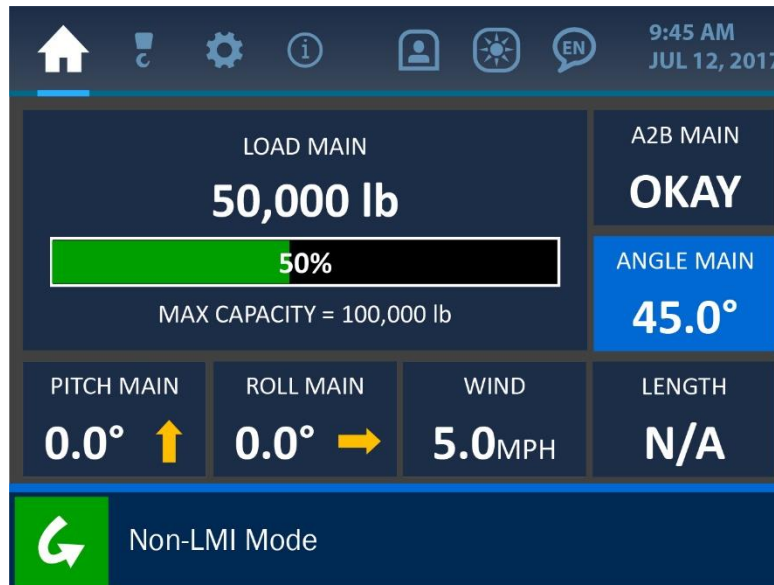

As illustrated above, the current boom angle is shown in degrees, to the resolution of 0.1°. Pressing anywhere directly overtop the Angle Indication Tile will open the Angle Menu, where angle limits can be adjusted.

Angle Limits

The Angle Limits Menu should initially show the default values for a Maximum of 180° and a Minimum of -180°. This simply ensures that the angle transducer is given its full potential range of operation, though these values can be changed at any time to accommodate special circumstances of operation.

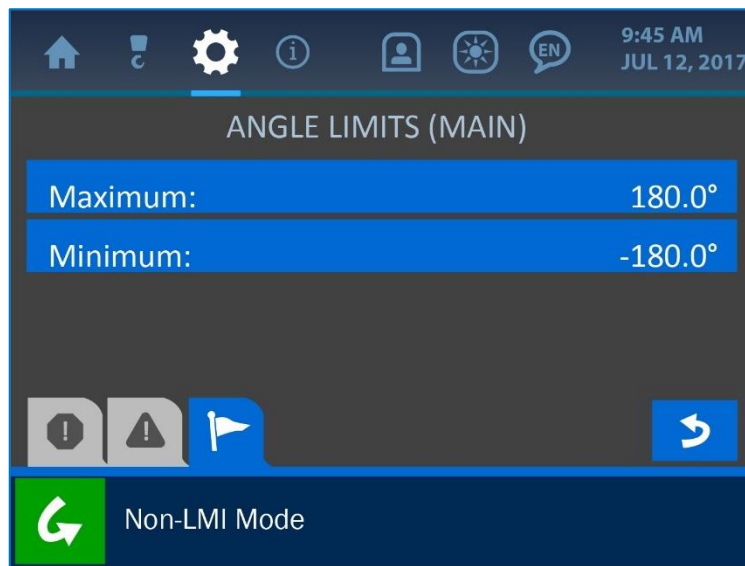

To change either of these values, simply press the screen directly overtop the desired limit value to open the Value Entry Screen, as shown below.

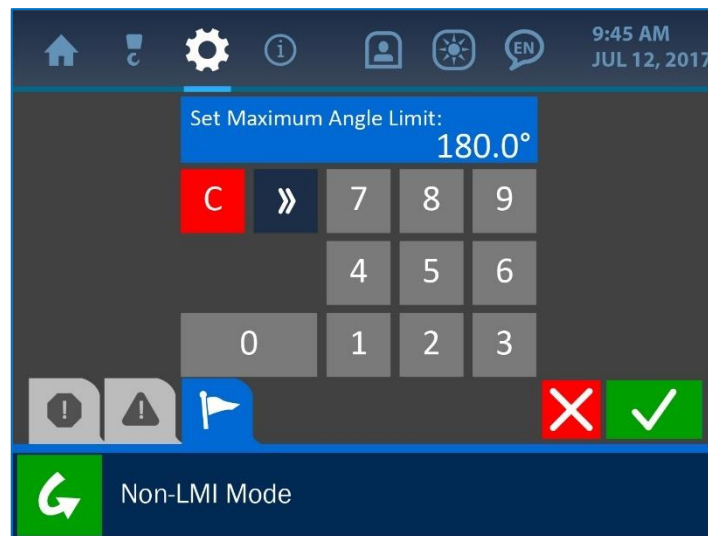

Once the Value Entry Screen is opened, use the keypad to enter the desired value for the parameter, and press the (green) Accept Button to save the change. **NOTE: See 'The User Interface' section of this manual for more information on the Value Entry Screen.**

2.4. Level Indication

Shown below is the Home Screen, with the Level Indication Tiles (Pitch and Roll) emphasized.

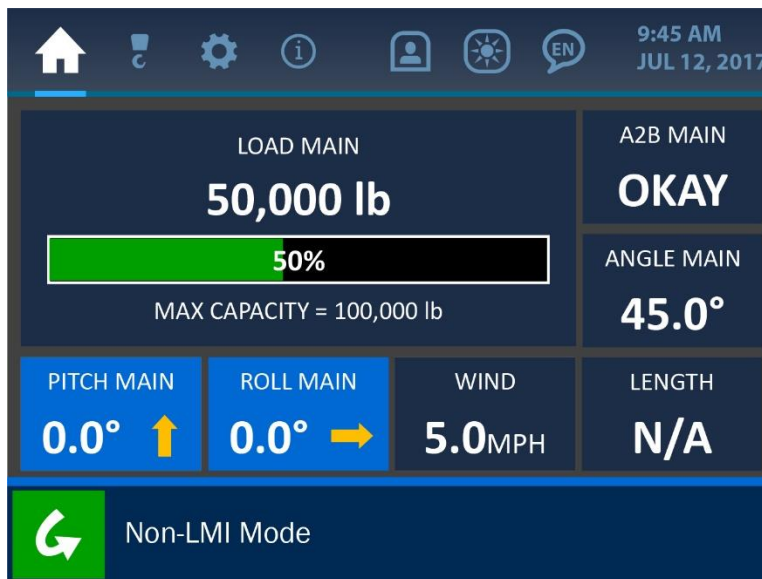

As illustrated above, the current machine pitch and roll values are shown in degrees, to the resolution of 0.1°. Pressing anywhere directly overtop either parameter will open the Level Menu, as shown below.

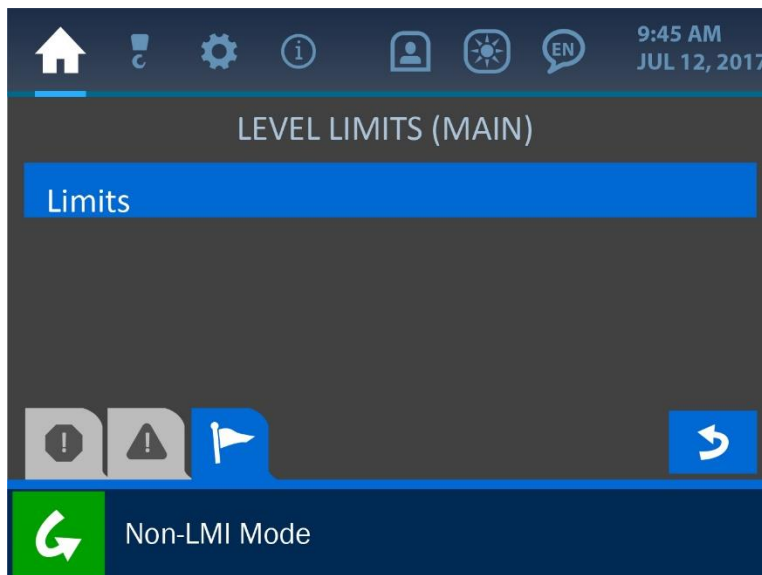

Level Limits



The level limits are defined as a maximum and minimum values for machine pitch and roll, according to the particular machine the system is installed on. These values are factory-set but can be changed in the field as necessary, by pressing the screen overtop any limit. This will open the Value Entry Screen, as shown below.

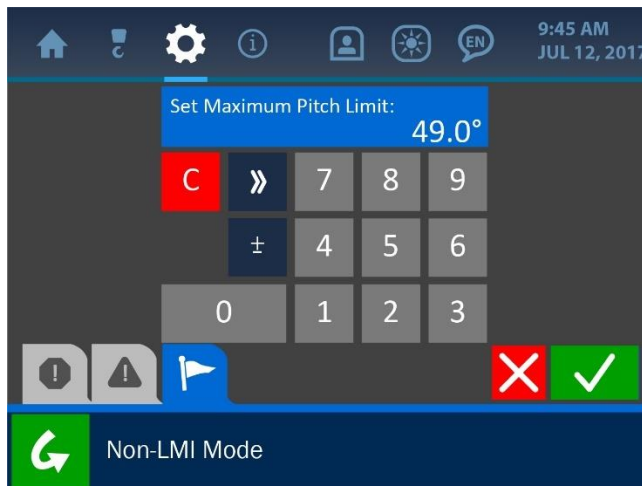

Once the Value Entry Screen is opened, use the keypad to enter the desired value for the parameter, and press the (green) Accept Button to save the change.

NOTE: See 'The User Interface' section of this manual for more information on the Value Entry Screen.

2.5. Wind Speed Indication

Shown below is the Home Screen, with the Wind Speed Indication Tiles emphasized. In addition to indicating wind speed, this component will also sense and display temperature on the Home Screen.

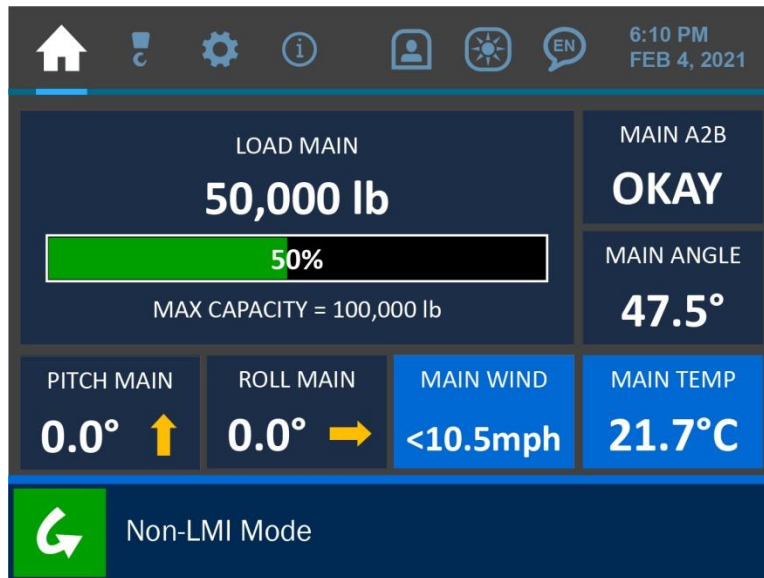

As illustrated above, the current wind speed is shown in miles per hour, to the resolution of 0.1mph. Pressing anywhere directly overtop either parameter will open the Windspeed Limit Menu, as shown below.

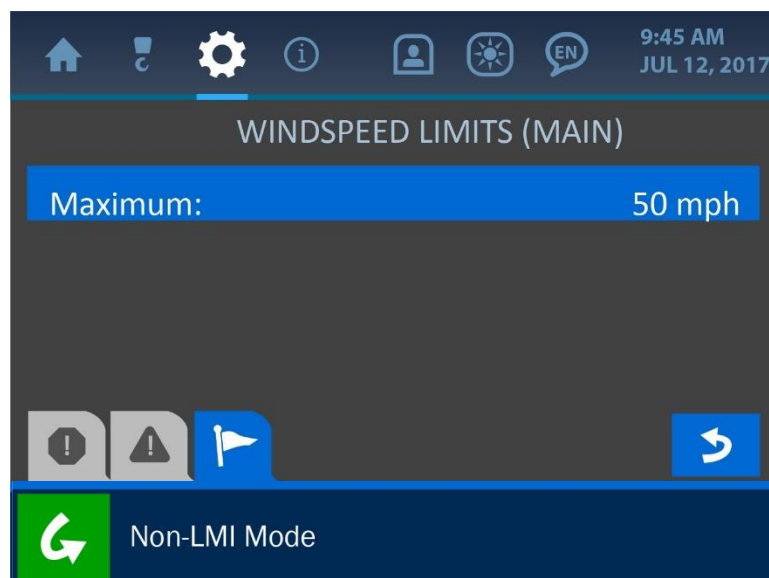

Pressing directly overtop the 'Maximum' option for the Wind Speed Limit will open the Value Entry Screen, where this limit can be adjusted as necessary.



Once the Value Entry Screen is opened, use the keypad to enter the desired value for the parameter, and press the (green) Accept Button to save the change.

NOTE: See 'The User Interface' section of this manual for more information on the Value Entry Screen.

2.6. Adding a Spare Transducer

The LMI 4 panel allows for spare components to be added to the system quickly and easily. First, enter the user permission code to gain access to the required menus for this operation (see the section: *Entering the Permission Level Code* of this manual).



Select the transducer type to open further options for the component. From the transducer menu, an inactive component can be added to the system, or an already active component can be disabled, swapped or removed.

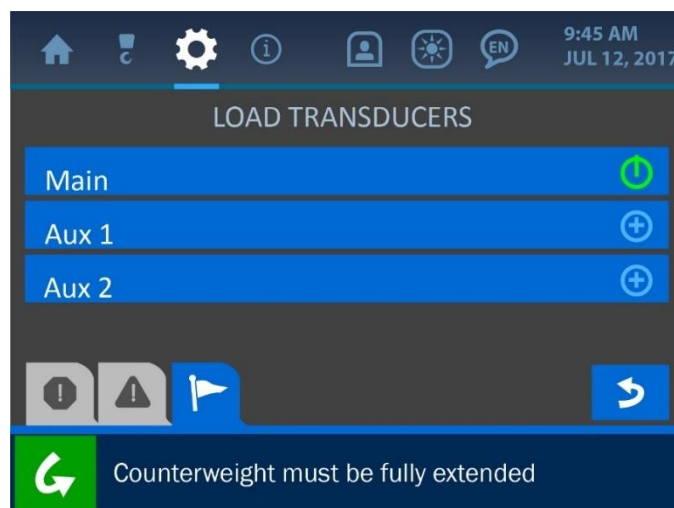



The **disable** function will keep a component's ID number registered in the system and assigned to that particular transducer but will not accept communications from it. A disabled transducer will not trigger system alarms as it is unable to send signals to the display panel. The **swap** function will disable one component and enable another in its place. The **remove** function will completely ignore communication from a component and reassign its ID number to another component when necessary.

Once a new component is selected to be added or swapped for another, the system will prompt the user to initiate a scan for a new transducer. Press the 'Scan' button to start the scan.

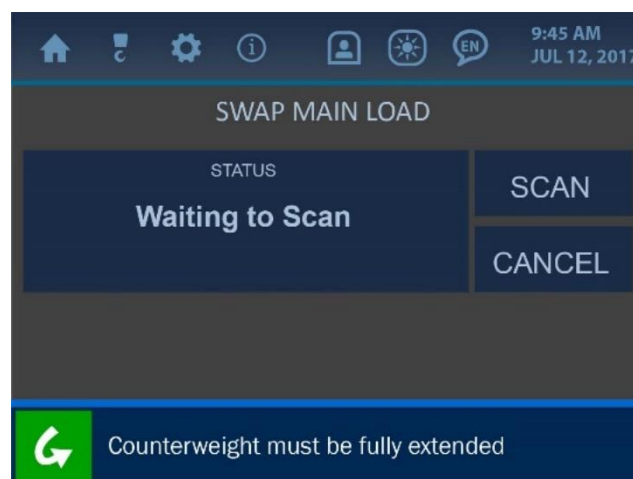

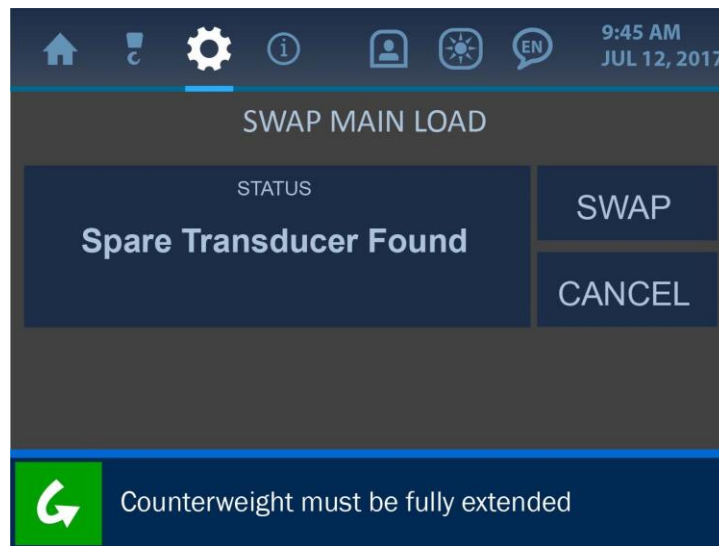

Once found, the message: 'Spare Transducer Found' will be displayed. Press the 'Swap' button to complete the operation. The system will then perform the replacement, while displaying accompanying messages on the screen. All calibration and identification assignment will also be handled automatically within the system.

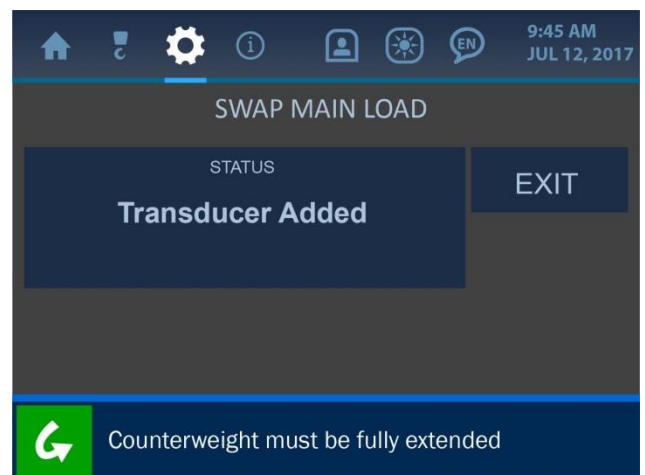
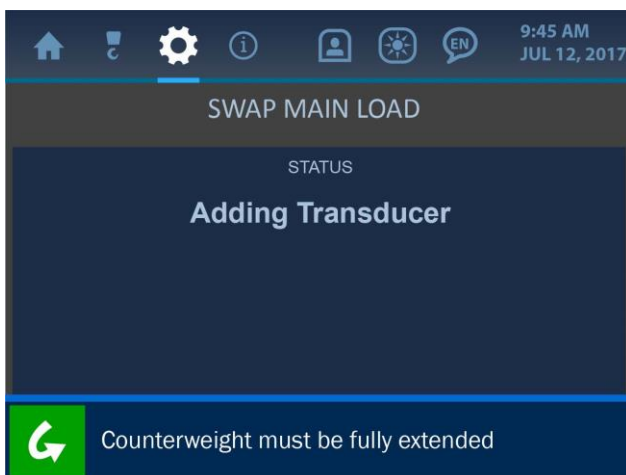

After the new transducer has been added to the system, press the 'Exit' button to return to normal operation.

2.7. Using the USB Functions (Data Logging and Upgrading the System Firmware)

The LMI 4 system introduces new functions available via a built-in USB port, located on the back of the display panel as shown in the illustration below. The USB port can be used to log data as well as upgrade the system firmware. Both of these functions are described in the following sections.



Data Logging

To begin logging data from the LMI 4 system display panel, first insert a FAT formatted USB drive into the panel's USB port. Next, enter the Supervisor Permission Code to access the data logging option in the Settings Menu (see the section: *Entering the Permission Level Code* of this manual).

Next, navigate to the Logs Menu (screenshot shown below) by entering: Settings / Panel / Logs. Select the option 'Download to USB' to begin downloading logs to the USB drive. This may take several minutes, depending on how many logs are being downloaded.

NOTE: While logs are being downloaded to the USB drive, the display panel's functionality is limited and will not operate as an LMI or Non-LMI system component.

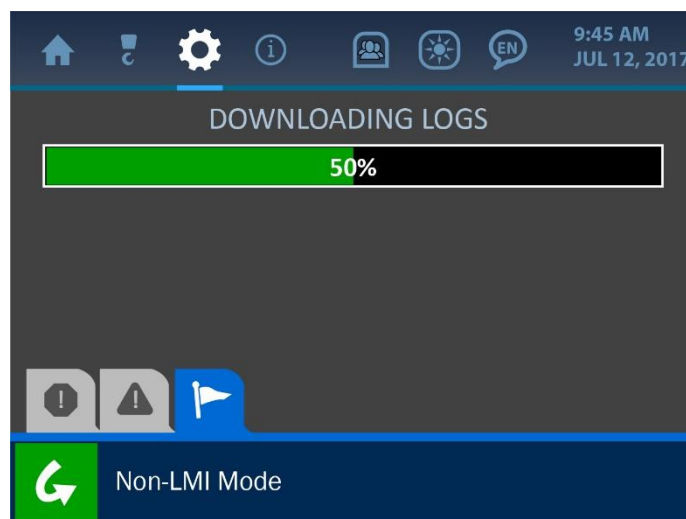
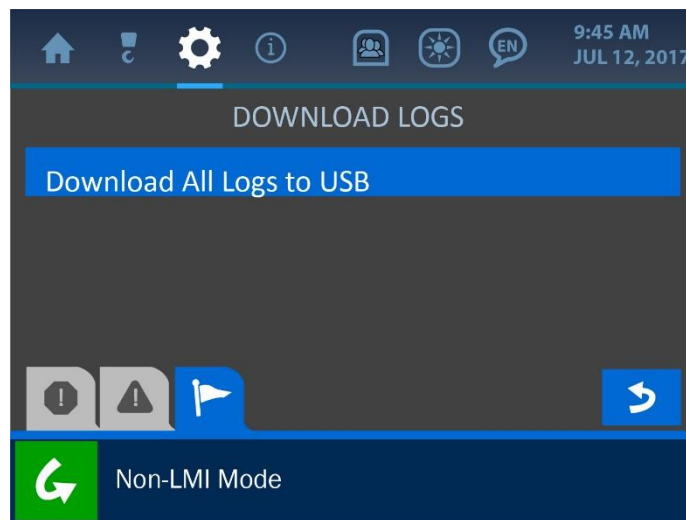

Once finished, the system will indicate that the download is complete and the USB drive can be safely removed from the display panel.

Viewing the Data Logs

The downloaded logs will be saved to the USB drive with a title indicating the date and time saved. The naming format is described below:

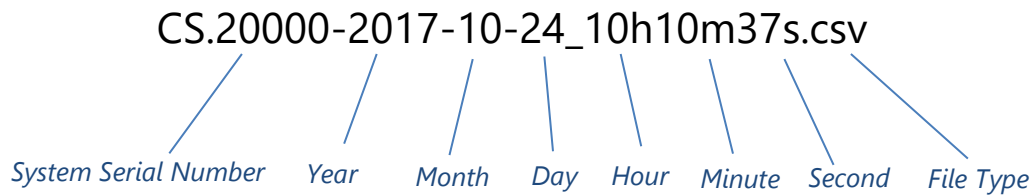

Once the USB drive is inserted into a computer, open Microsoft Excel and create a new workbook, as shown in the screenshot below.

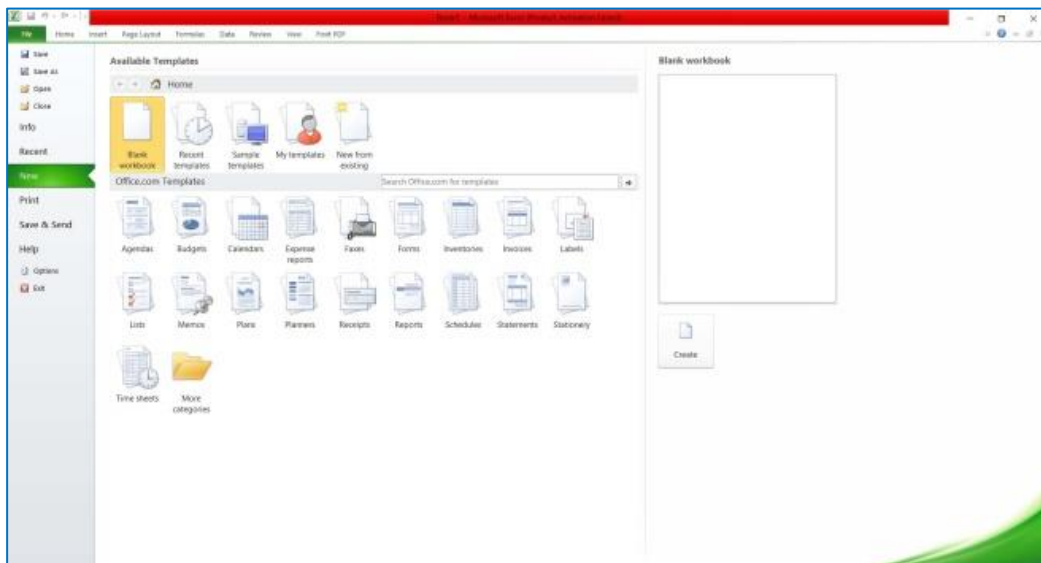

From the new workbook interface, click to open the 'Data' tab located along the top of the menu bar. Then, from the 'Get External Data' section of the 'Data' tab, click the option *From Text*.

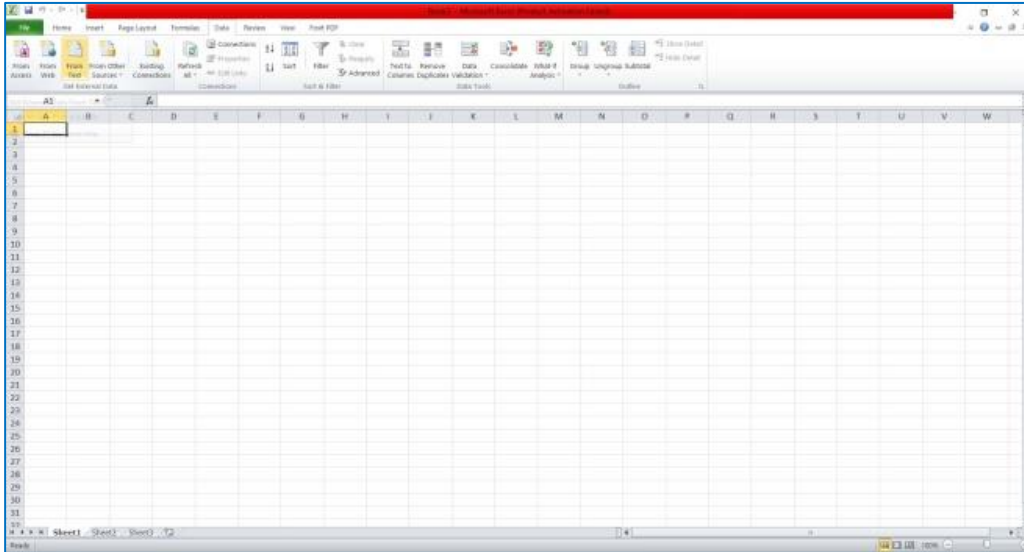

Upon selection, an 'Import Text File' window will open, allowing the user to navigate to the log files on the USB drive. Select the appropriate csv file and click 'Import'.

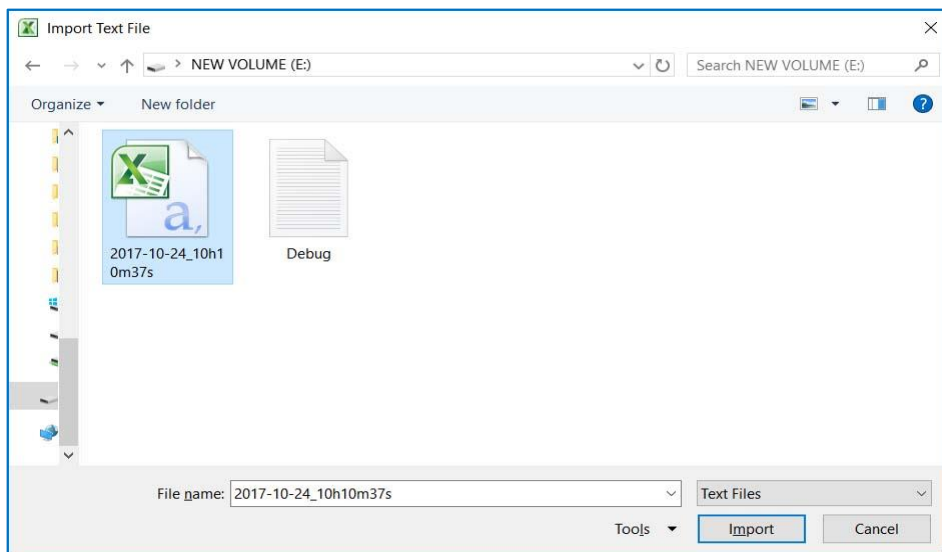

At this point, a 'Text Import Wizard' will be displayed, allowing for various options and customization of the data. From the 'File origin' dropdown box, select the option '65001: Unicode (UTF-8)' and click the 'Next' button. Then, deselect the 'Tab' option in the 'Delimiters' section and select the 'Comma' option. Click 'Finish' to close the wizard.

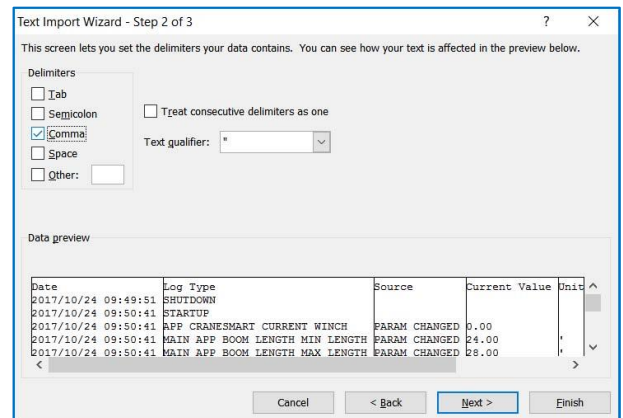
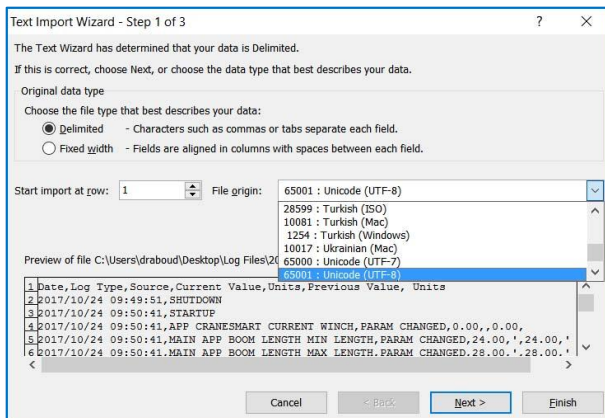

The program will open one final dialogue box, asking where the data should be placed. The default setting of 'Existing worksheet: =\$A\$1' is appropriate – simply click 'OK' to close the dialogue box and view a spreadsheet of the saved logs.

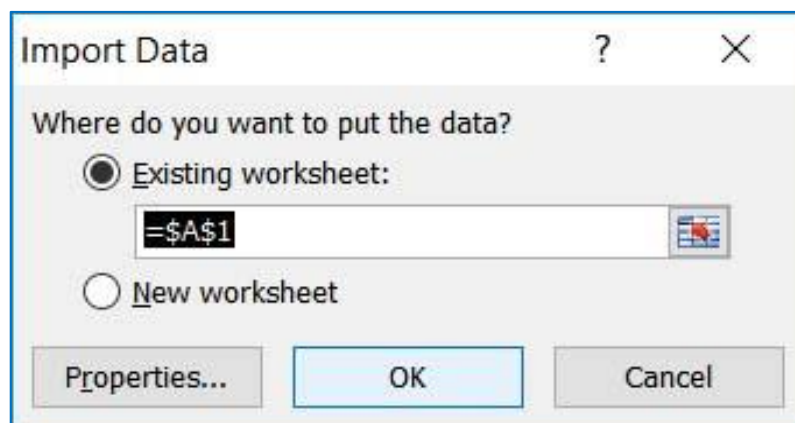

The logs will now be displayed as a detailed and columned list, marked by a timestamp (left column) and describing qualities such as: parameter changes, transducer output values, alarms and limits breached, bypass button presses and start-up / shutdown points.

A	B	C	D	E	F	G	H	I	J	K	L	M	N	O	P	Q
1	Date	Log Type	Source	Current Value	Units	Previous Value	Units									
2	10/24/2017 9:49	SHUTDOWN														
3	10/24/2017 9:50	STARTUP														
4	10/24/2017 9:50	APP CRANESMART CURRENT WINCH	PARAM CHANGED	0		0										
5	10/24/2017 9:50	MAIN APP BOOM LENGTH MIN LENGTH	PARAM CHANGED	24	'	24	'									
6	10/24/2017 9:50	MAIN APP BOOM LENGTH MAX LENGTH	PARAM CHANGED	28	'	28	'									
7	10/24/2017 9:50	APP LOGGER SHUTDOWN PERIOD	PARAM CHANGED	60		60										
8	10/24/2017 9:50	APP CRANESMART CURRENT WINCH	PARAM CHANGED	0		0										
9	10/24/2017 9:50	PARAM LIST	MAIN A2B STATE	2												
10	10/24/2017 9:50	PARAM LIST	MAIN ANGLE STATE	2												
11	10/24/2017 9:50	PARAM LIST	MAIN ANGLE USER MAX ANGLE	180	°											
12	10/24/2017 9:50	PARAM LIST	MAIN ANGLE USER MIN ANGLE	-180	°											
13	10/24/2017 9:50	PARAM LIST	MAIN ANGLE ZERO VALUE	89.5	°											
14	10/24/2017 9:50	PARAM LIST	MAIN LEVEL STATE	2												
15	10/24/2017 9:50	PARAM LIST	MAIN LEVEL USER PITCH MAX	49	°											
16	10/24/2017 9:50	PARAM LIST	MAIN LEVEL USER PITCH MIN	-49	°											
17	10/24/2017 9:50	PARAM LIST	MAIN LEVEL USER PITCH ZERO	0	°											
18	10/24/2017 9:50	PARAM LIST	MAIN LEVEL USER ROLL MAX	49	°											
19	10/24/2017 9:50	PARAM LIST	MAIN LEVEL USER ROLL MIN	-49	°											
20	10/24/2017 9:50	PARAM LIST	MAIN LEVEL USER ROLL ZERO	0	°											
21	10/24/2017 9:50	PARAM LIST	MAIN LOAD STATE	2												
22	10/24/2017 9:50	PARAM LIST	MAIN LOAD USER MAX	1000000	lb											
23	10/24/2017 9:50	PARAM LIST	MAIN LOAD USER MIN	0	lb											
24	10/24/2017 9:50	PARAM LIST	MAIN LOAD USER ZERO	0	lb											
25	10/24/2017 9:50	SNAPSHOT	MAIN LOAD VALUE	0	lb											
26	10/24/2017 9:50	SNAPSHOT	LOAD CHART MAX LOAD	216000	lb											
27	10/24/2017 9:50	SNAPSHOT	MAIN ANGLE CURRENT VALUE	-89.5	°											
28	10/24/2017 9:50	SNAPSHOT	LOAD CHART OVERHANG	1.71	'											
29	10/24/2017 9:50	SNAPSHOT	LOAD CHART TIP HEIGHT	-22	'											
30	10/24/2017 9:50	SNAPSHOT	MAIN LEVEL PITCH VALUE	0	°											
31	10/24/2017 9:50	SNAPSHOT	MAIN LEVEL ROLL VALUE	0	°											
32	10/24/2017 9:50	SNAPSHOT	MAIN A2B VALUE	0												

Upgrading the System Firmware

To upgrade the system firmware, first ensure that the USB drive to be used is FAT formatted, and that the appropriate *Upgrade.bin* file is located in its root directory. Then, enter the Supervisor Permission Code to gain access to the USB Menu in the system (see the section: *Entering the Permission Level Code* of this manual).

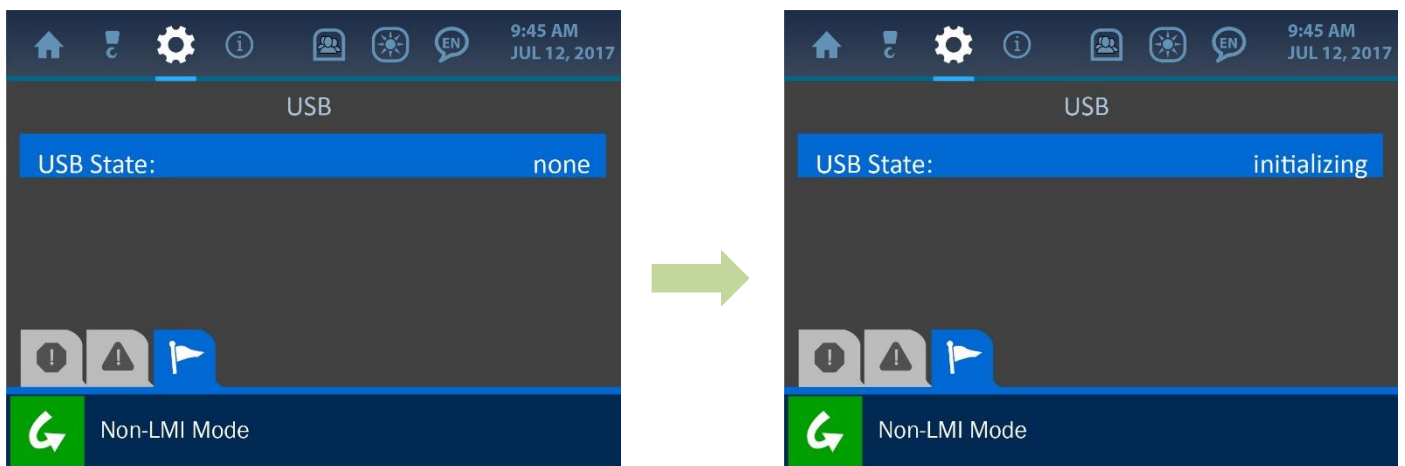

Next, enter the USB Menu, by entering: Settings / Panel / USB. Before a USB drive is inserted into the display panel, the USB Screen will indicate that there is no device detected. Once a USB drive is inserted, the status will change to 'initializing', and will display various parameters once the contents of the drive have been read by the system. As shown in the following screenshot, these include: the device name, disk size, and the version of the available upgrade.

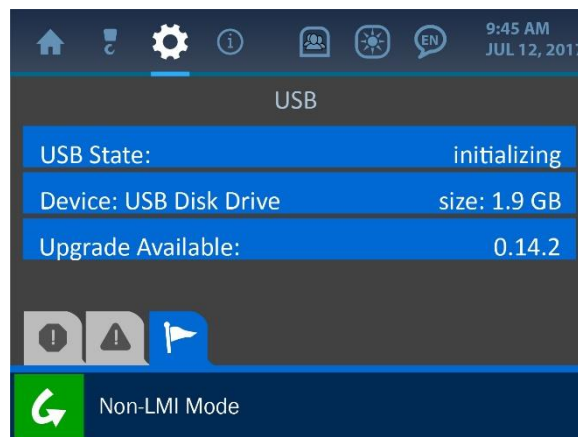

To upgrade the system firmware, simply press the screen directly overtop the upgrade version number. The system will prompt the user to confirm the upgrade, then will display the following progress screen:

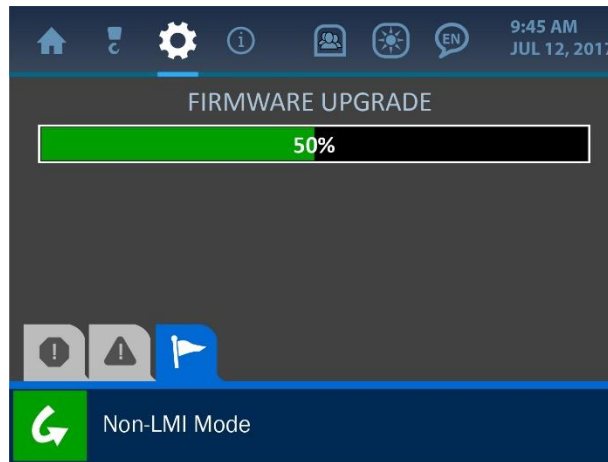

Depending on what kind of upgrade is being installed, the update may take up to 15 minutes. Once the upgrade is complete, the system will restart, run a diagnostic routine and return to normal functioning. At this point, the system will be upgraded and the USB drive can be safely removed from the display panel.

3. The Configuration Menu

The Configuration Menu is symbolized by the boom hook icon at the top of the display and can be accessed by pressing the screen directly overtop this icon. This menu shows the major parameters that vary with each machine and are crucial to ensuring that the system's logic, displays and calculations will be accurate. This section describes these major parameters: Winch and POL (parts of line).

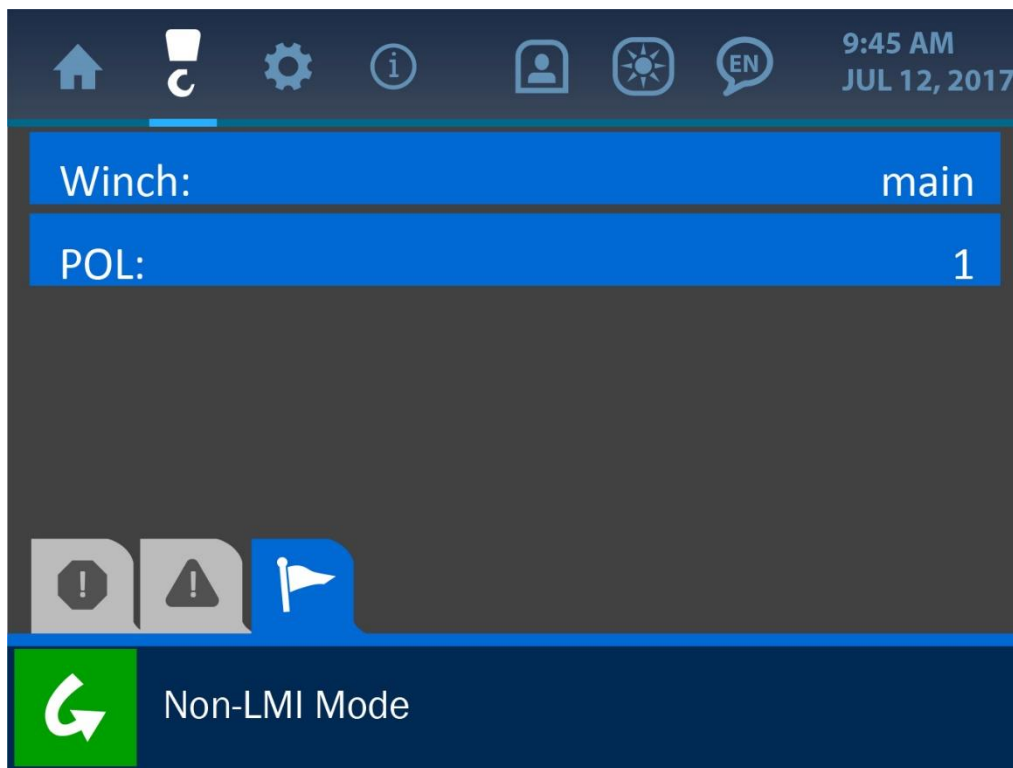

NOTE: Typically, the winch parameter is factory-set and cannot be changed without the assistance of a Cranesmart Service Technician. The POL can be changed as needed, though this operation requires a Supervisor Permission Code (see the 'Supervisor Access Screens' section of this manual for an explanation of how to gain access to restricted areas of the system).

3.1. Winch

The winch parameter indicates that the system is using the 'main' winch line. This parameter is factory-set and cannot be changed.

3.2. POL (Parts of Line)

The POL (Parts of Line) can be changed by simply selecting a new value from the POL menu. Once selected, the system will prompt for confirmation that the parameter should be changed. Press the green 'Check' button to accept the change.

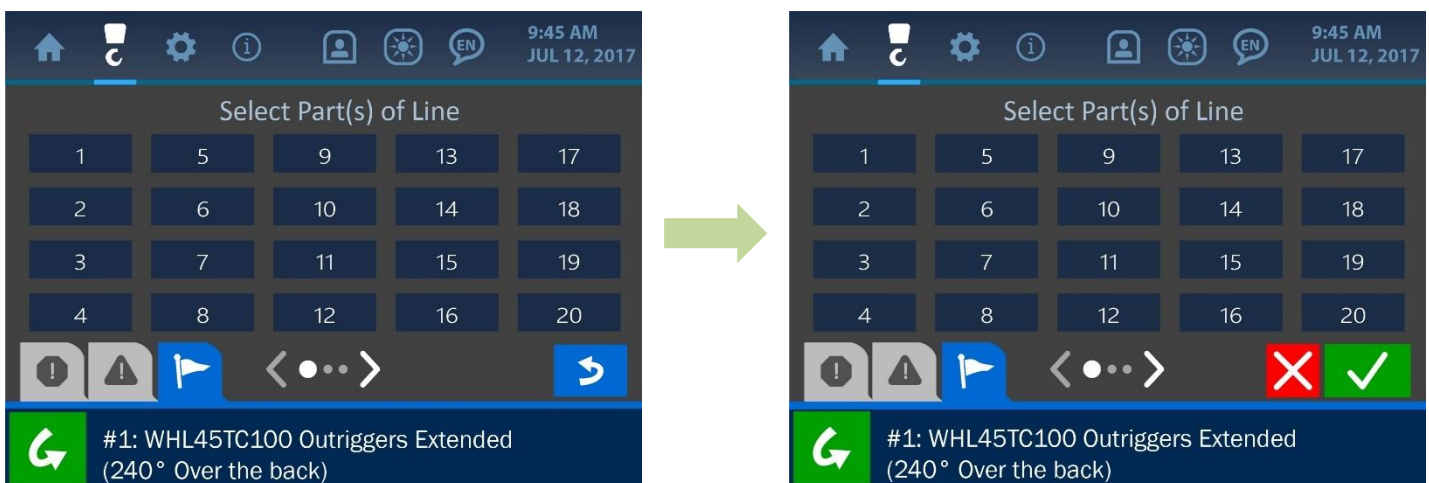

4. The Settings Menu

The Settings Menu is symbolized by the gear icon at the top of the display and can be accessed by pressing the screen directly overtop this icon. This menu offers many important options to the operator for how the system functions and displays information. The Settings Menu is shown below, and explanations of its various components follow. **NOTE: For the sake of this manual, the supervisor access level of this menu is shown. Normal user access will have less options available than those shown for this description.**

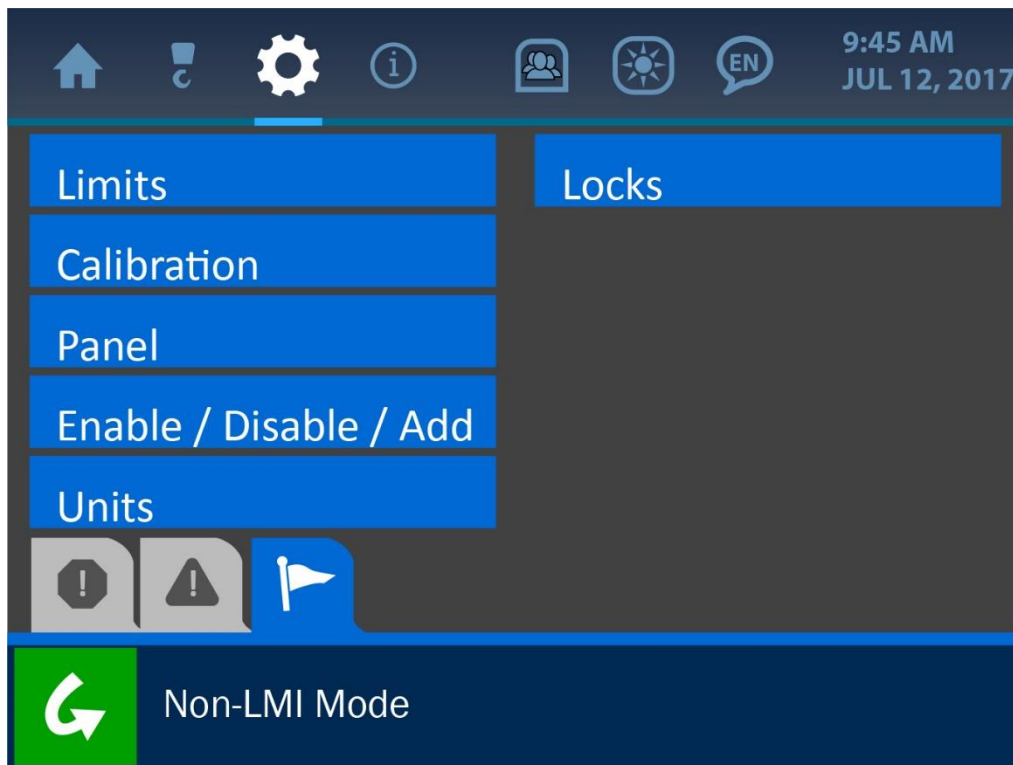

4.1. Limits

The Limits Menu presents all the various parameters that can be adjusted to define what the machine's safe zones of operation are. As listed and shown on the following screenshot,

these limit categories are: Load, Angle, Overhang, Tip Height and Level. For more information on each of the listed limits see *The Normal Operation* section of this manual.



4.2. Calibration

The Calibration Menu lists the system indicators that require proper adjustment for accurate operation. As listed and shown on the following screenshot, these indicators are: Load, Angle and Level. Each of these calibrations is described in its respective section of this manual.



Load Calibration



The Load Calibration Menu is accessible only after the Supervisor Permission Code has been entered (see the section *Entering the Permission Level Code* of this manual). Once made accessible, this menu displays the current settings for the following parameters:

ADC Zero: indicates the system's analog to digital conversion value when there is no load on the hook. **(NOTE: This value cannot be directly changed).**

ADC Span: indicates the system's analog to digital conversion value when the maximum possible load is on the hook (before the system shows a load alarm). **(NOTE: This value cannot be directly changed).**

Load Zero: indicates the displayed load value when there is no load on the hook

Load Span: indicates the displayed load value when there is a maximum load on the hook (before the system shows a load alarm)

To change the 'Load Zero' or 'Load Span' values, simply press the screen directly overtop the target option to enter the Value Entry screen for this parameter.

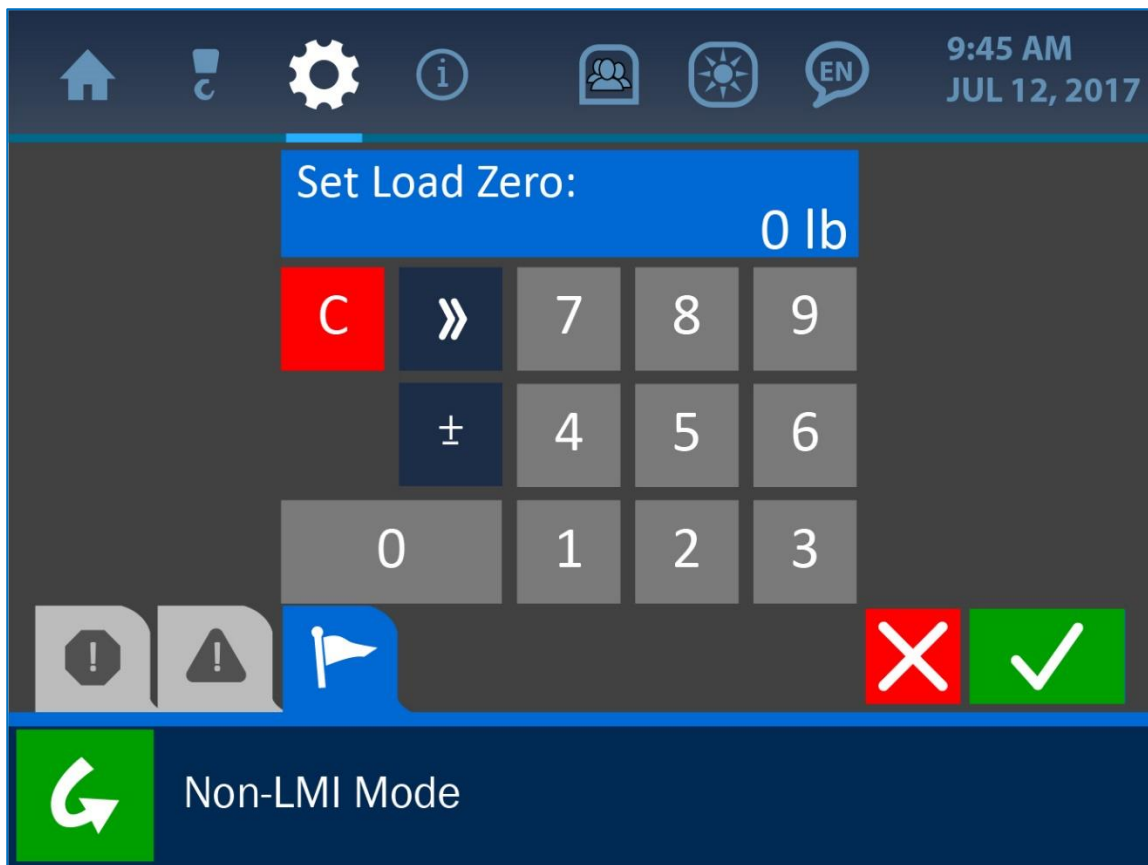

Once the Value Entry Screen is opened, use the keypad to enter the desired value for the parameter, and press the (green) Accept Button to save the change.

NOTE: See 'The User Interface' section of this manual for more information on the Value Entry Screen.

Angle Calibration

The Angle Calibration Menu allows the operator to set a target angle and orientation for the angle transducer.

Concerning the Target Angle, set this value to what the system should be reading at a known boom angle. If the machine boom is currently at 0° but the system is displaying a different value, using the Target Angle Option will compensate for this discrepancy, by introducing an offset value in order to make the display more accurate.

NOTE: The boom can be set to any angle, as long as that angle is known to be accurate by some other means (for example a level, applied to the boom horizontally or vertically). The resolution of the angle indicator is 1.0°.



To change the target angle value, simply press the screen directly overtop the target angle option to enter the Value Entry screen for this parameter.



Once the Value Entry Screen is opened, use the keypad to enter the desired value for the parameter, and press the (green) Accept Button to save the change.

NOTE: See 'The User Interface' section of this manual for more information on the Value Entry Screen.

The Position option simply ensures that the system displays the boom angle correctly by indicating which side of the boom the transducer is mounted on (in relation to the operator's viewpoint). As shown in the following screenshot, selecting this option will open a submenu, allowing the choice of either the left or right side of the boom.

Selecting either option for the orientation will automatically enter that selection into the system and return the user to the Angle Calibration Screen.

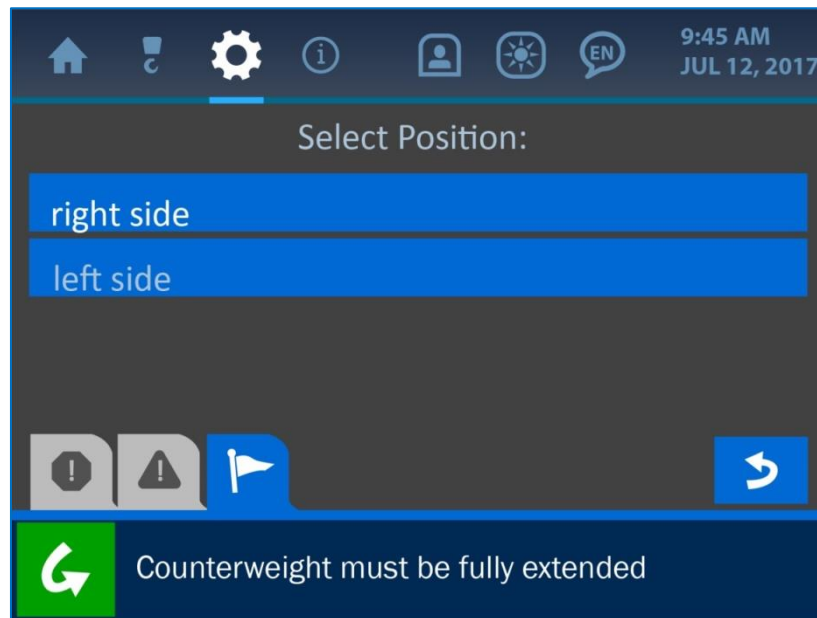

Level Calibration



The first option listed the Level Calibration Menu is 'Auto Calibration'. To use the automatic calibration method, position the machine so it is level (within 0.5°) and press the Auto Calibration Button. If calibration is successful, the message: 'Roll Offset set Successfully' will be displayed in the Notification Bar at the bottom of the screen, and the values for Pitch and Roll should display as 0.0° on the Home Screen. If calibration has failed, or if the level transducer has been disabled, the message: 'Level Transducer is Disabled' will be shown instead to indicate the problem.

NOTE: If at any point, the machine is positioned more than 5.0° out of level (either pitch or roll) the system will enter an alarm state, and the load indication will only show the weight on the line alone, without accounting for angle limits.

The 'Position' button on the Level Calibration Menu offers the option to either normalize or invert the roll orientation.

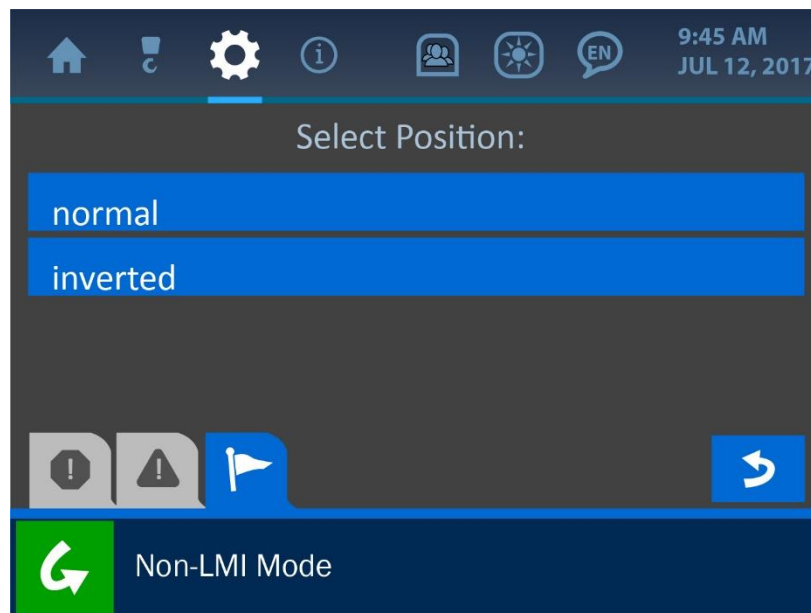

For example, if the *normal* option is selected, a machine roll to the right side of 2.5° (relative to the operator's viewpoint) would display as a roll value of 2.5° and an arrow pointing to the right. The *inverted* option would show the arrow pointing left, to indicate how much and in which direction the machine should move in order to re-establish a level position.

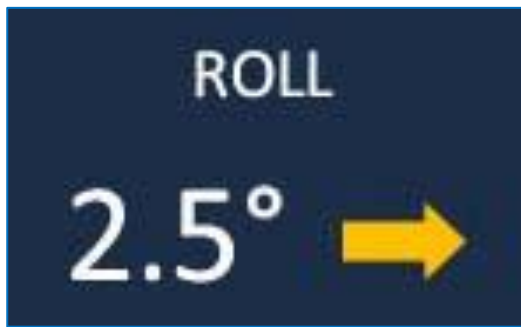

Boom Length Calibration



To calibrate the boom length of the machine, first ensure that the boom is fully retracted. Once retracted, press the 'Set Fully Retracted' button. Then, fully extend the boom and press the 'Set Fully Retracted' button. The system is now calibrated for the specific boom length of the machine.

Powerline Calibration

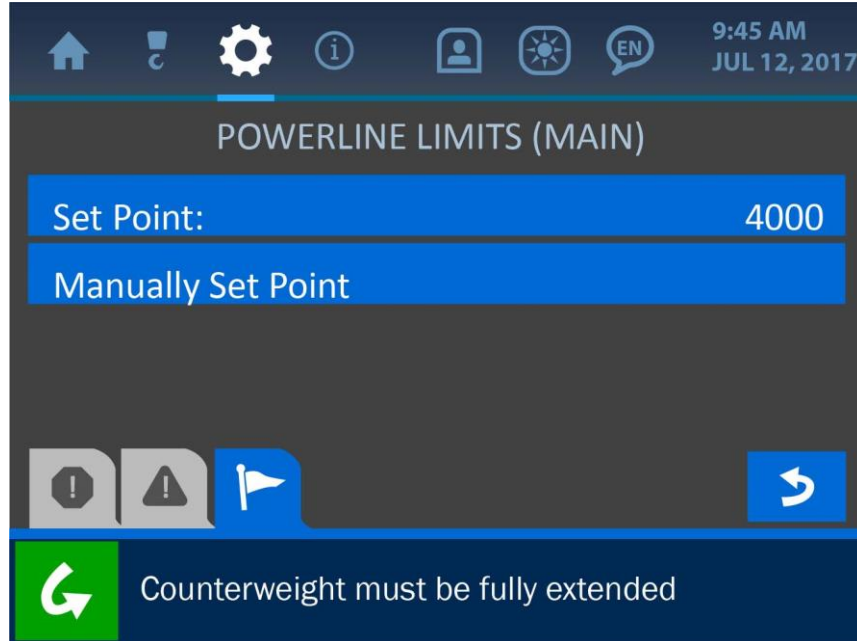

To set the powerline limit automatically, move the machine boom to the position that is to be marked as the safety limit in terms of distance to a powerline. Once in position, press the 'Set Point' button at the top of the menu. The A/D value will be automatically set and displayed based on the sensed proximity to the powerline. To set this limit manually, press the 'Manually Set Point' button and enter a value for the system.

NOTE: The system will warn the operator once the proximity to a power line exceeds 80% of the limit value. The machine will only engage the shutoff function after the powerline limit is exceeded.

4.3. Panel

The Panel Menu offers the options to: adjust the relay settings, machine type parameters, save or restore the panel and system settings, adjust the audio levels, and enter the USB and logging options.



Relay

The Relay Menu allows a supervisor to check on the relay status, adjust the operation mode (normally cold or normally hot) and select which components are controlled by the relay function.

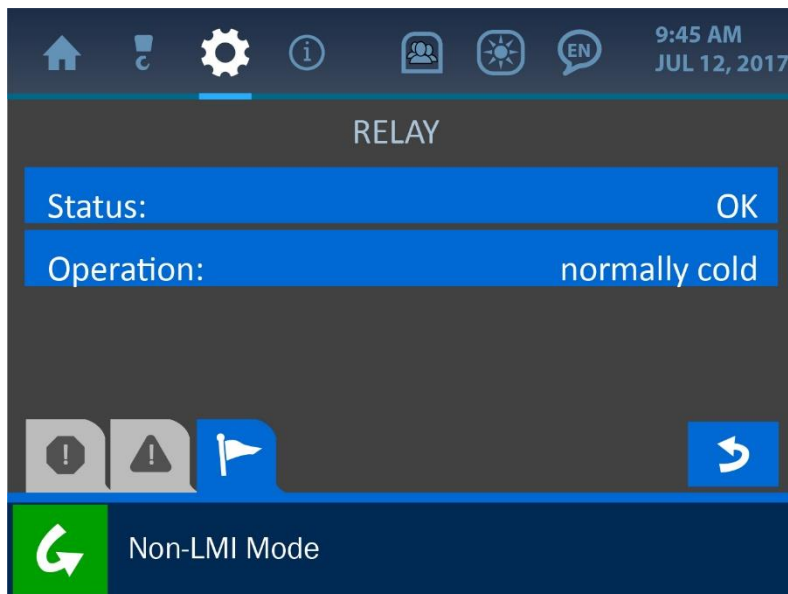

Parameters

The Parameters Menu allows a supervisor to adjust the single line pull parameter of the machine in use.

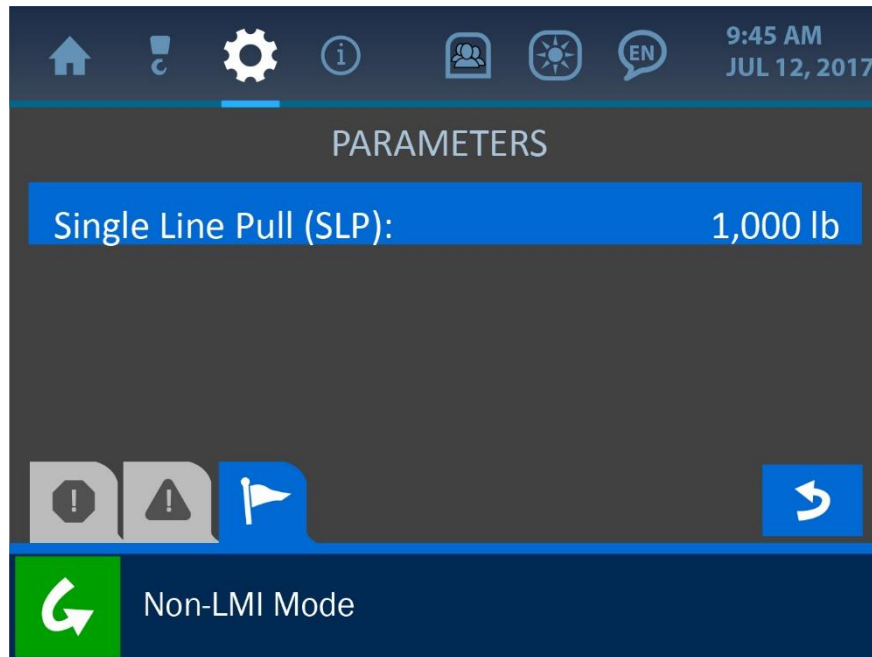

Save / Restore

From the Save/Restore Menu, the operator can choose to save the current system settings, or restore previous ones. Pressing either button will prompt a confirmation screen to ensure the right selection has been made.

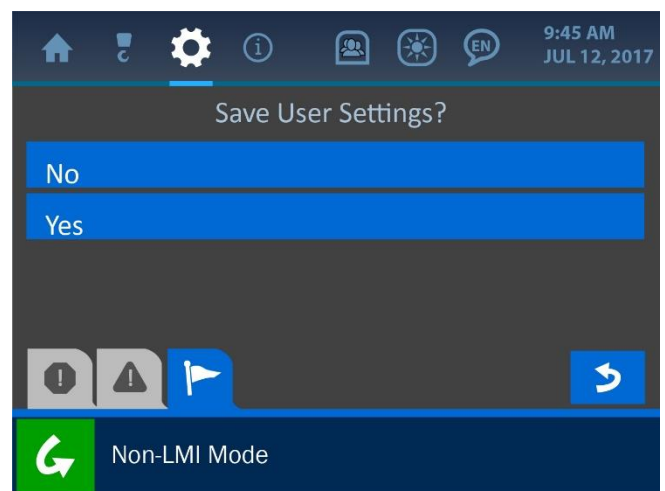
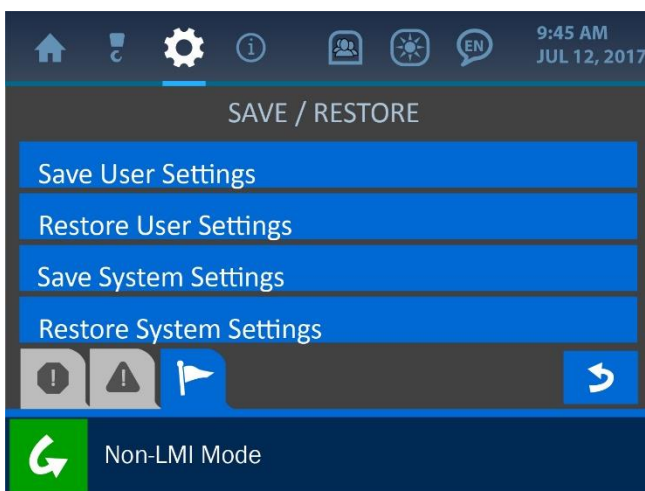

Audio

The Audio Menu allows the supervisor to enable or disable the alarm audio.

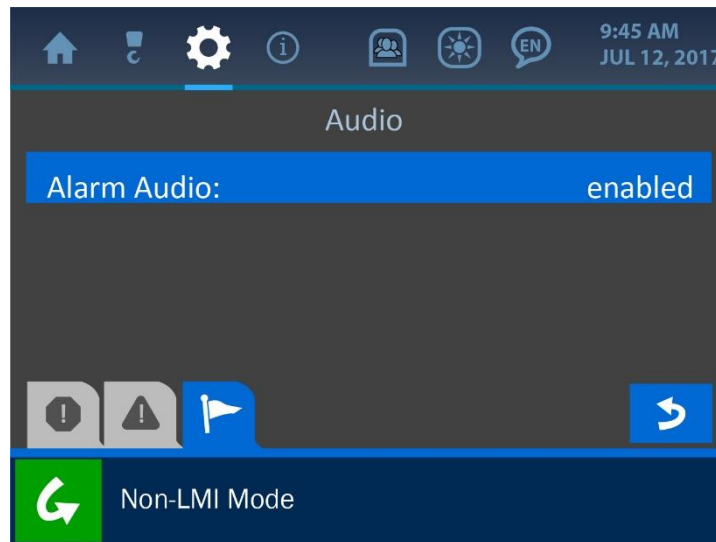

USB

The USB Menu allows the supervisor to update the system firmware, via a USB drive.

NOTE: See the section: 'Upgrading the System Firmware' of this manual for more information on using this function.

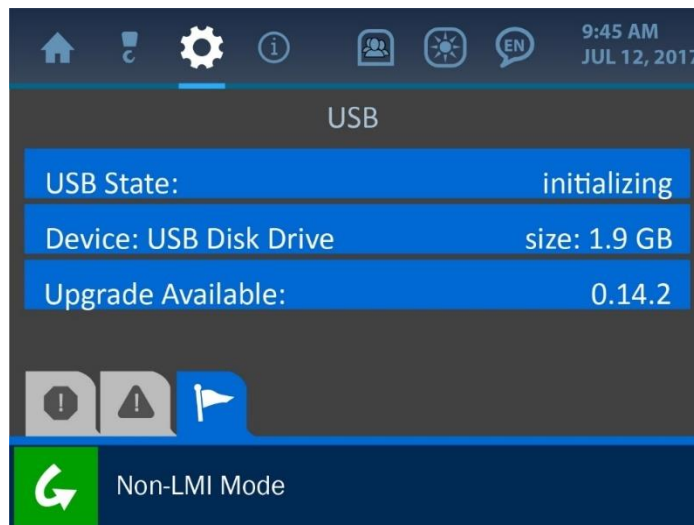

Logs

The Logs Menu allows the supervisor to download the systems logged data to a USB drive. The screenshot below shows the default display when no USB drive is detected.

NOTE: See the section: 'Using the USB Functions' of this manual for more information.

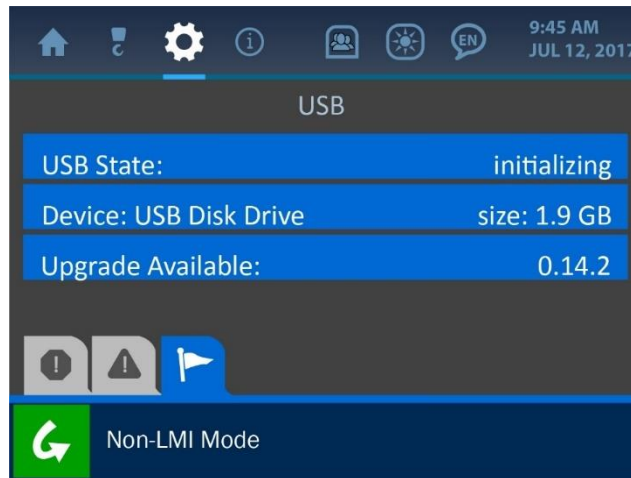

4.4. Enable / Disable / Add

This menu is used to add or remove components from the system and active display. Simply select which transducer to affect, and either activate or deactivate it.

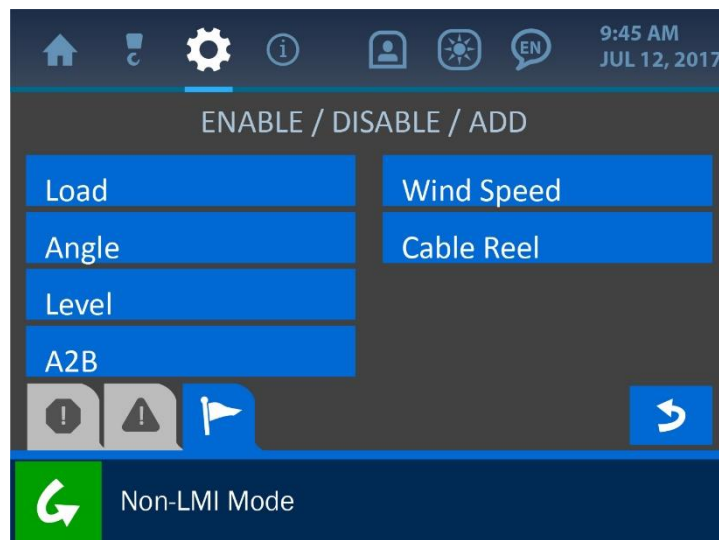

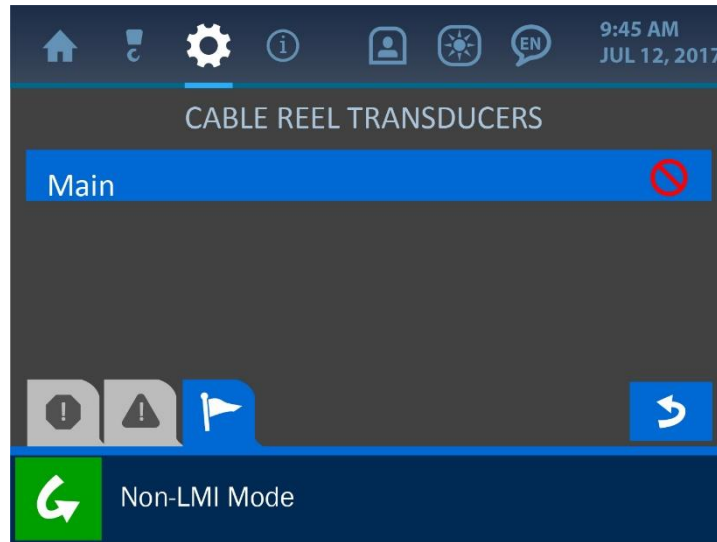

4.5. Units

This menu is used to toggle between metric and imperial units for the parameter display.

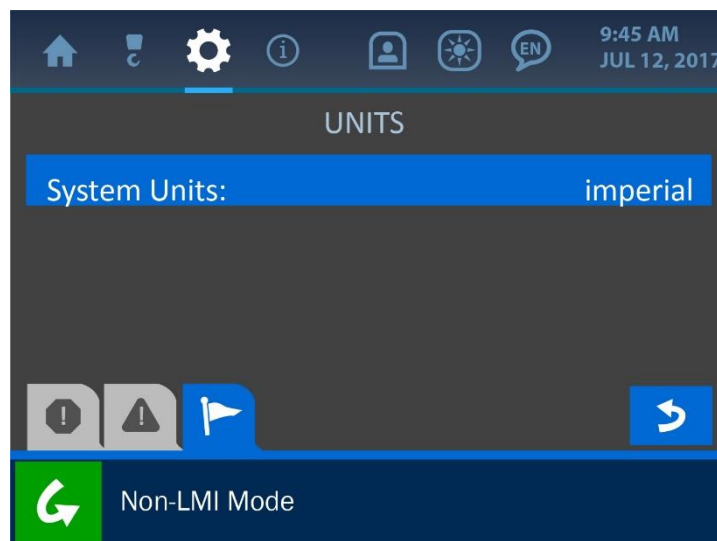

4.6. Locks

This menu is used to toggle between metric and imperial units for the parameter display.

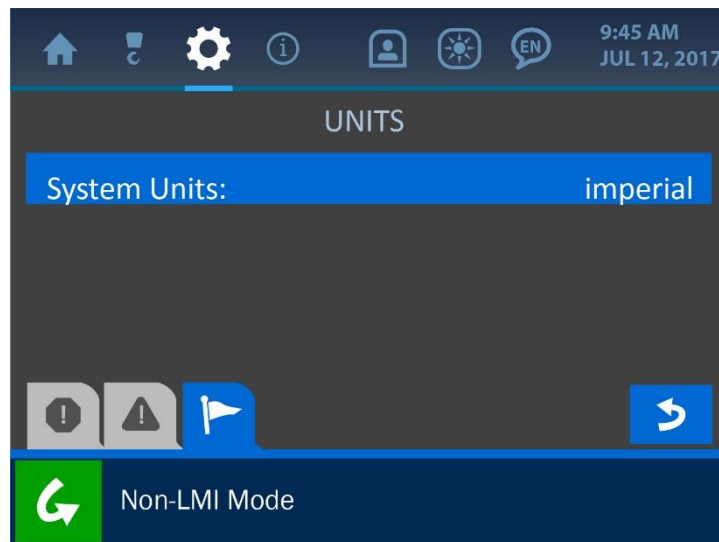

5. The Information Menu

The Information Menu is symbolized by the encircled 'i' icon at the top of the display, and can be accessed by pressing the screen directly overtop this icon. This menu offers options for displaying important information about the system such as: serial number, machine number, firmware version, system limits, transducer communication status and more. The Information Menu is shown below, and explanations of its various components follow.

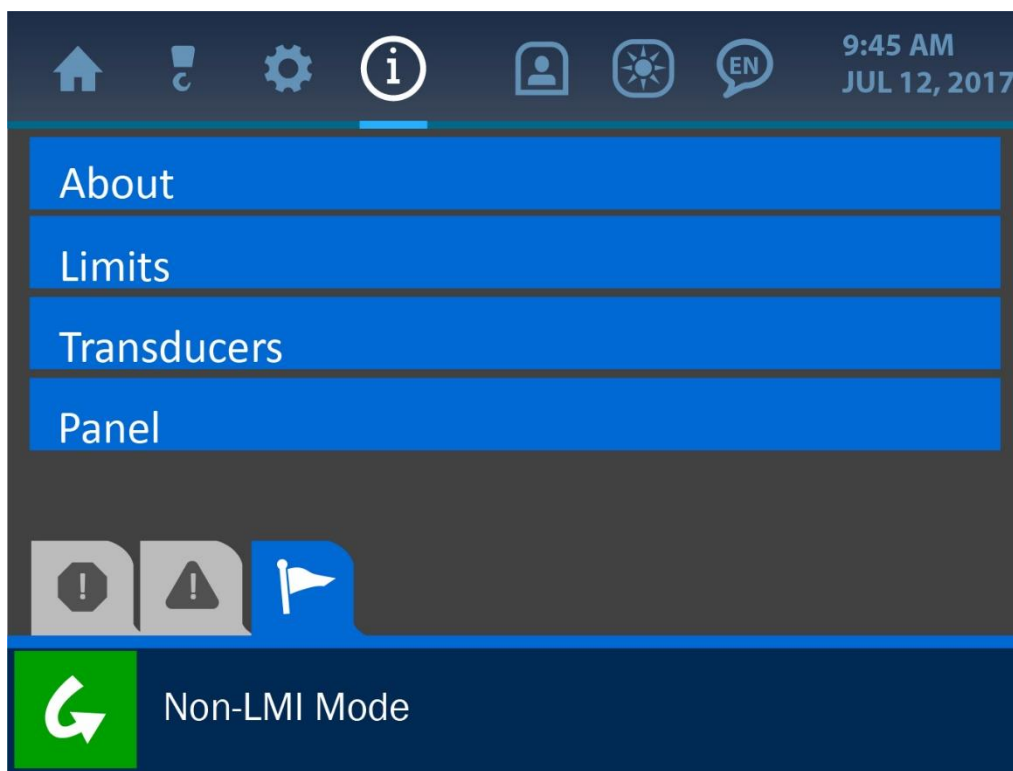

NOTE: The displays in the Information menu are for display purposes only. Other menus must be accessed to edit the settings and information found here.

5.1. About

The About option shows information related to the initial setup of the system. The system serial number, machine serial number, machine model, firmware version, and compiler timestamp can all be found in this menu.

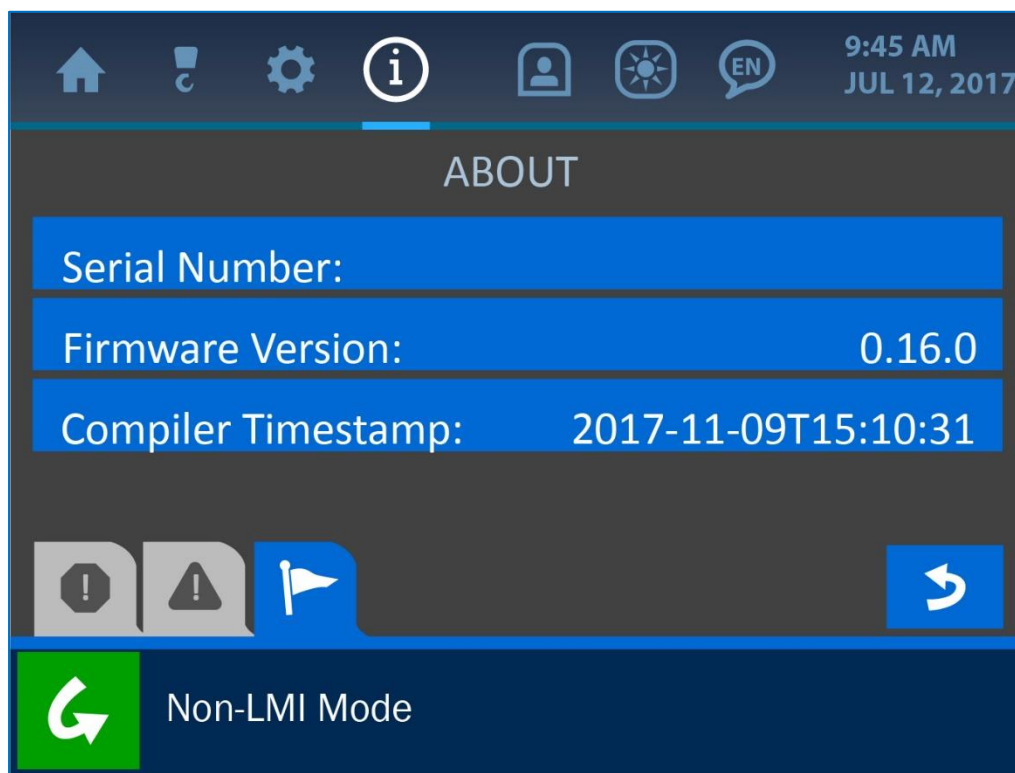

5.2. Limits

The Limits option offers displays of the set limits for all the major components, which are: load, angle, level and overhang/tip height.

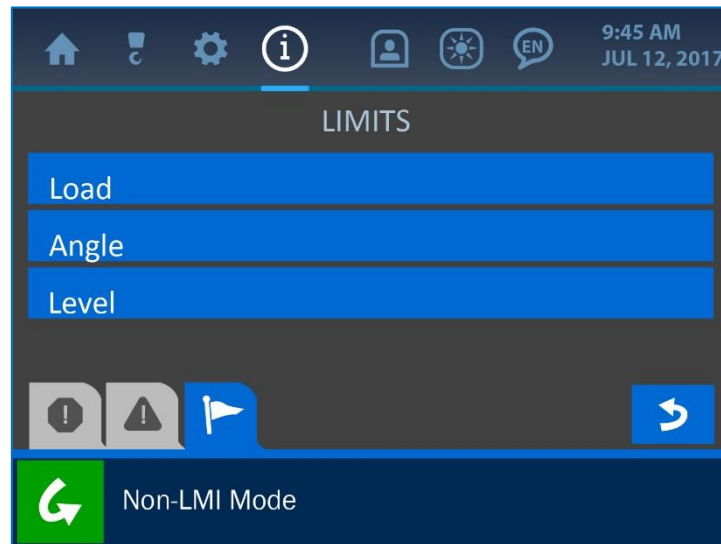

Press the screen overtop any of the options to reveal the set limits of that parameter.

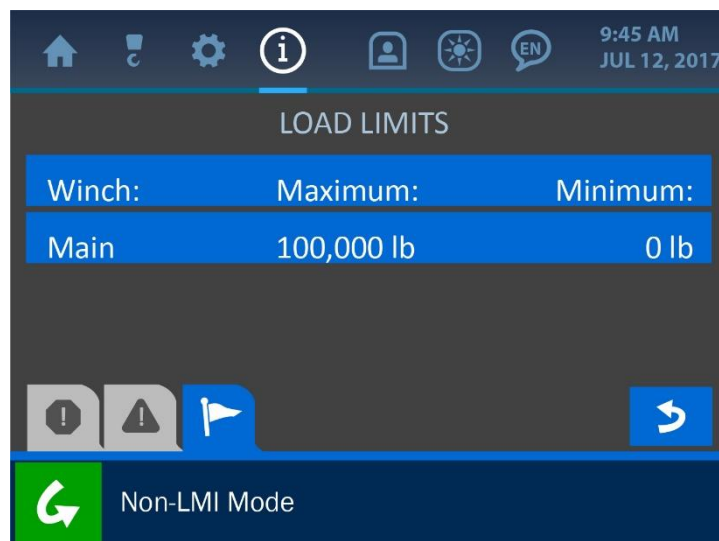

5.3. Transducer Stats – Radio

The Transducer Stats – Radio option shows each transducer’s packet count (an increasing count indicates open communication with the display panel) and signal strength.

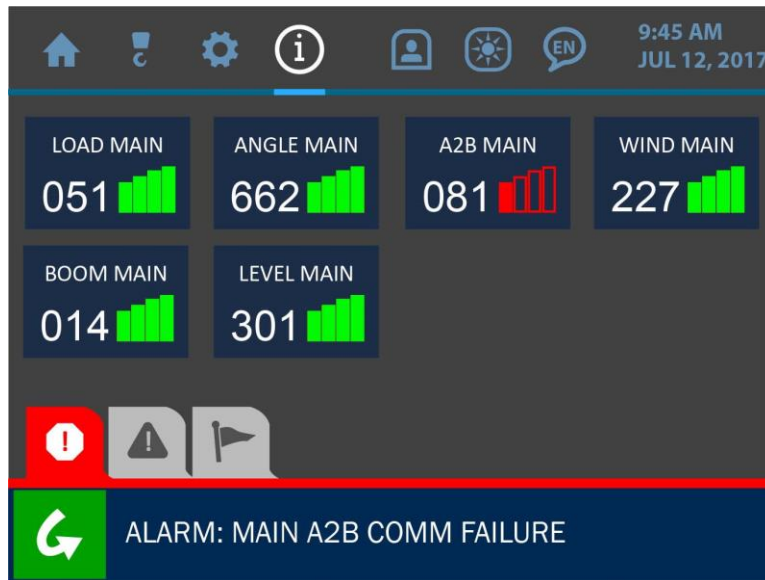

5.4. Transducers Stats – Info

The Transducer Stats – Info option shows each transducer’s ID and battery strength.

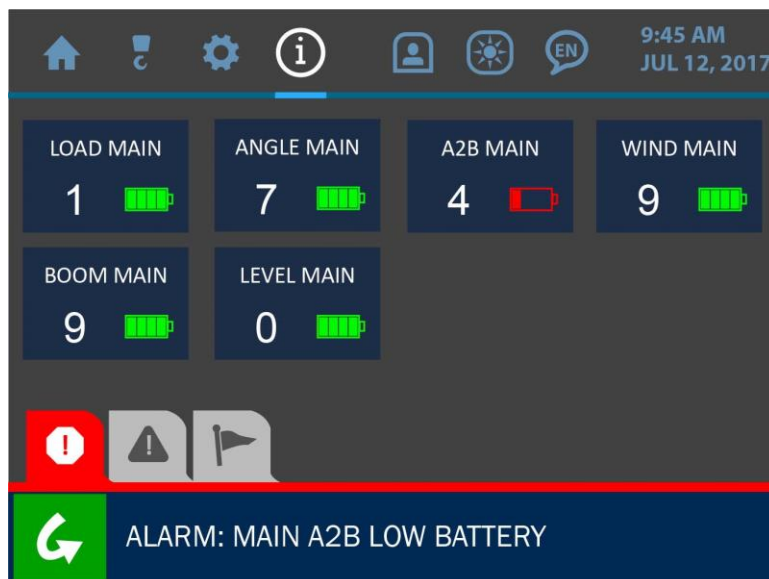

5.5. Panel

The Panel option shows information related to the display panel's relay function, relay mode and power settings, as shown in the screenshot below. The relay function is used (optionally) to limit or disable the machine in the case of an alarm. See the *Supervisor Access Screens* section of this manual for more information on configuring the panel's relay function.

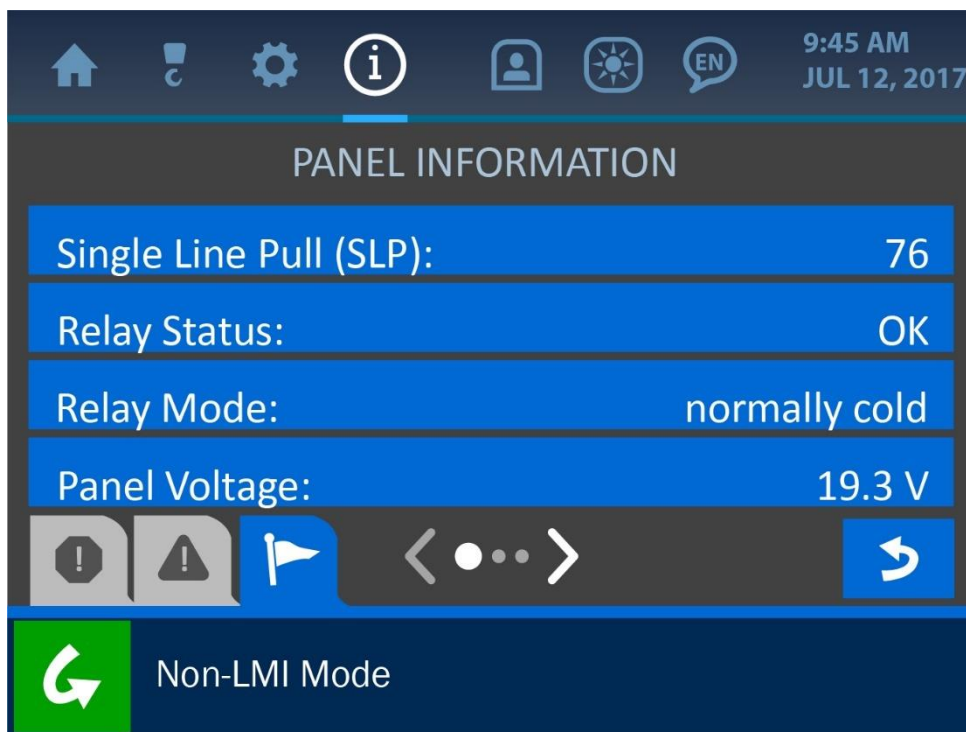

6. The Permission Menu

The Permission Menu is symbolized by the figure icon at the top of the display and can be accessed by pressing the screen directly overtop this icon. This menu is used to enter restricted areas of the system. A Supervisor Permission Code entered on the Permission Code Screen opens restricted areas to supervisors for safety control. A Service Code via the Service Portal Screen is used for technical maintenance and adjustment. The default Supervisor Permission Code from the factory is: 111, but can be customized to each system and changed at any time. **NOTE: For the sake of this manual, the supervisor access level of this menu is shown. Normal user access will have less options available than those shown for this description.**

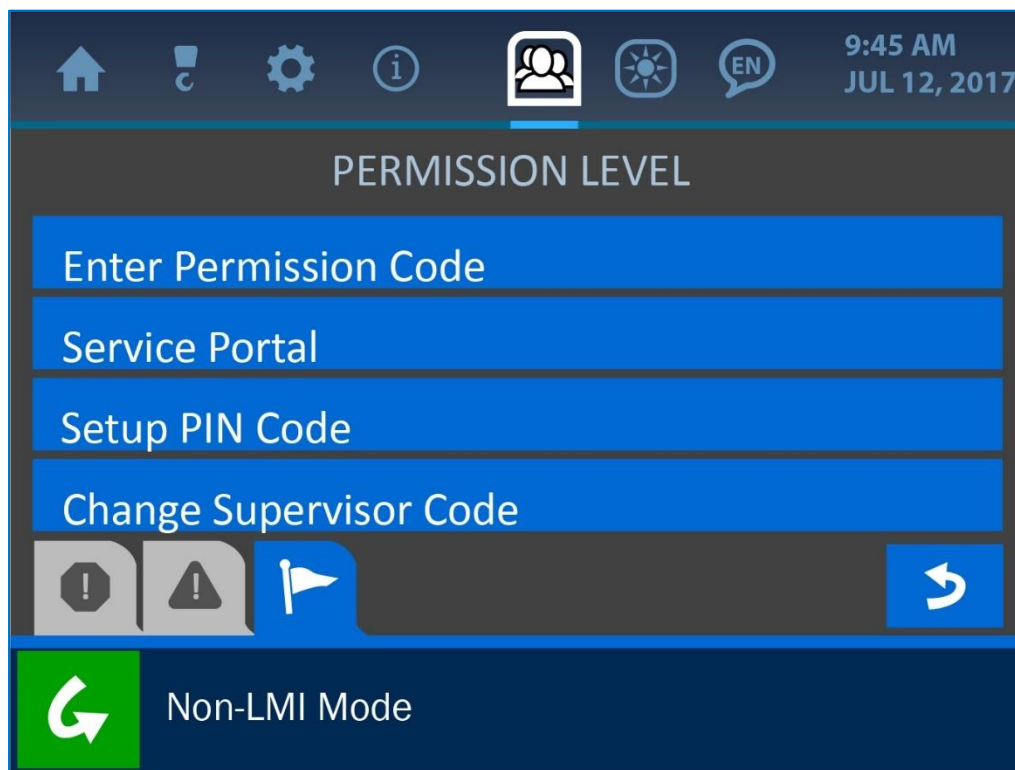

Once a permission code is entered into the system, a Supervisor Mode is enabled and new options become available in many of the system's menus. Refer to the following page for a visual layout of which screens are available in each mode. The Supervisor Access Mode will be active until the user navigates back to the Home Screen, at which time normal access resumes. (Refer to the *Supervisor Access Screens* section of this manual for a description of the supervisor options).

6.1 System Screen Flowchart

This illustration shows the basic layout of the system’s main menus and screens. The screens shaded in grey are the areas that are only available in Supervisor Access Mode, once the code has been entered.

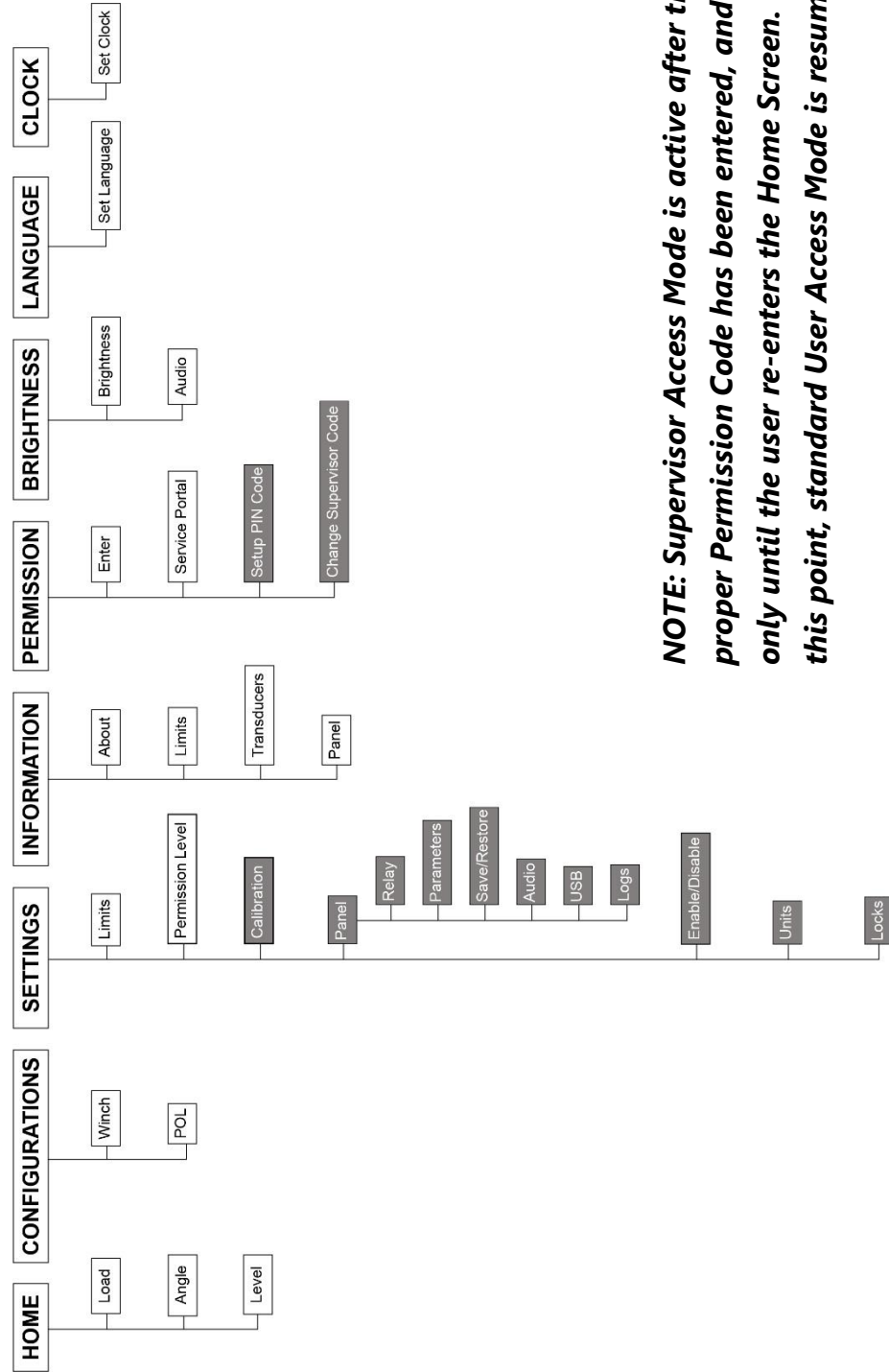

NOTE: Supervisor Access Mode is active after the proper Permission Code has been entered, and only until the user re-enters the Home Screen. At this point, standard User Access Mode is resumed.

6.2. Entering the Permission Level Code

To gain supervisor access to the system, press the 'Enter Permission Code' Button from the Permission Menu (symbolized by the figure icon at the top of the display). Then, enter the code via the keypad and press the (green) Accept Button to save the change to the system. To cancel this operation, simply press the (red) Cancel Button to return to the previous screen.

NOTE: The default Supervisor Permission Code from the factory is: 111, however this code can be customized to each system and changed at any time.

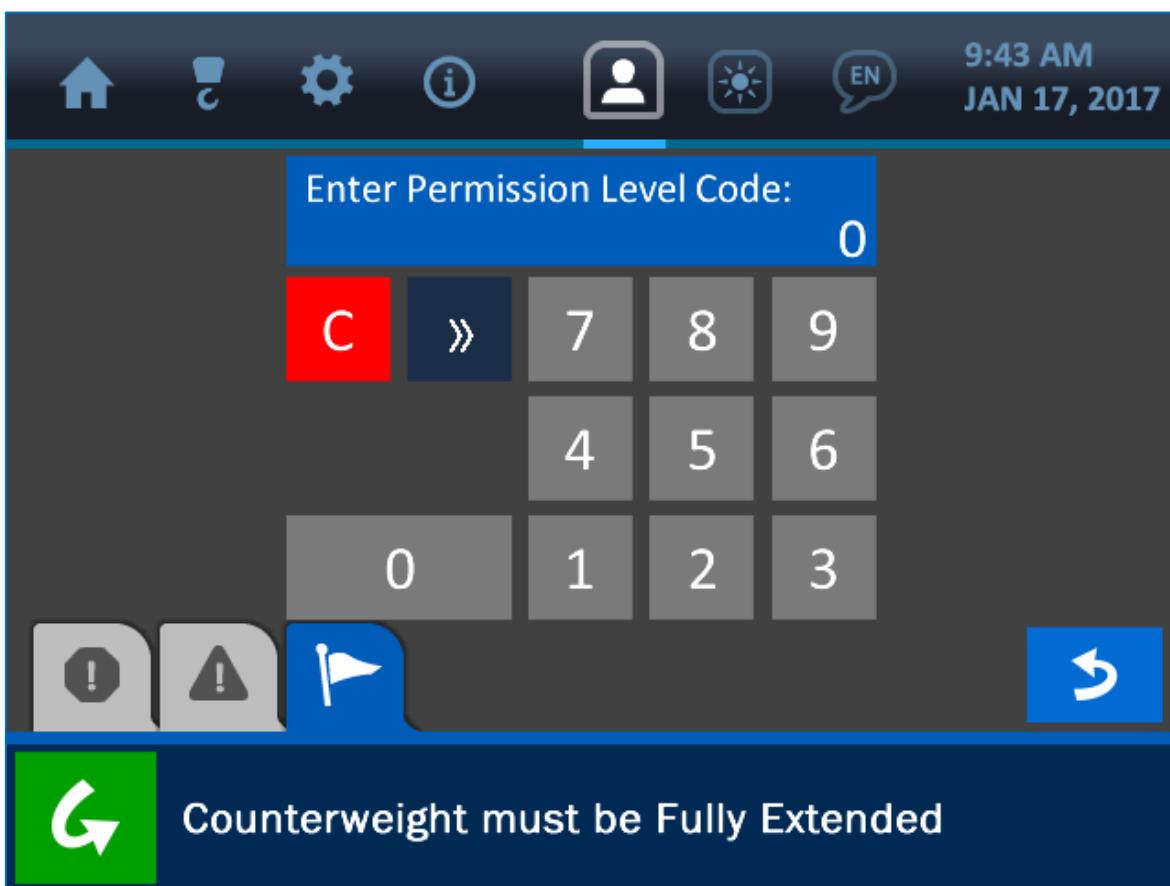

NOTE: See 'The User Interface' section of this manual for more information on The Value Entry Screen.

6.3. Supervisor Access Screens

Once the supervisor access level is gained (by entering the correct Permission Code) the Permission Menu symbol will be changed to reflect the new setting, and the following listed screens will now be made available. **NOTE: As noted earlier, these screens will no longer be available once the user cancels the Supervisor Access Mode by re-entering the Home Screen.**

Settings / Panel Menu:

- **Relay:** The Relay Screen offers options for adjusting how the relay function (shutoff option) operates, including whether the shut off is normally hot or cold, and which components it will affect. For example, the panel can be configured to interrupt the winch up function to prevent the operator from damaging the machine. Overload, A2B, Angle and Level can also be used to shut down the machine in unsafe conditions.



- **Radio:** The Radio Menu is used to set the transducer IDs and frequency, to ensure they can properly communicate with the display panel (this is also where replacement transducers can be assigned a frequency band and ID number).



- **Parameters:** The Parameters Menu is used to set the machine type and various dimensions so that the logic calculations are correct and able to display accurately. These values are pre-set in the factory but can be changed as necessary.

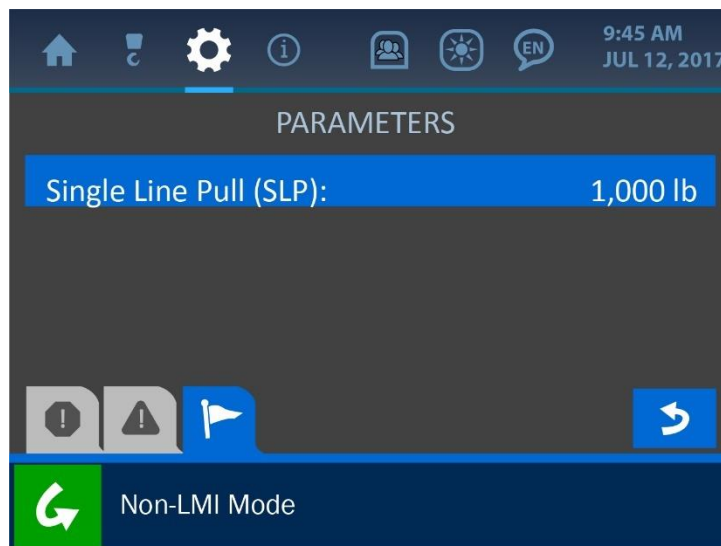

- **Audio:** The Audio Screen is used to either enable or disable the alarm sound. Pressing the Banner Button will open the Audio State Submenu, where either state can be selected and saved into the system.

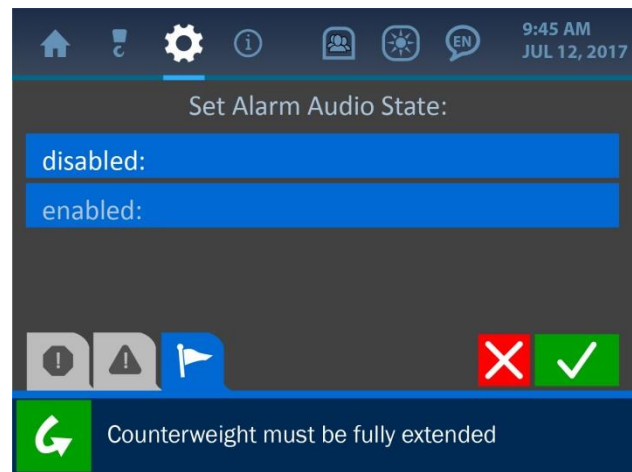
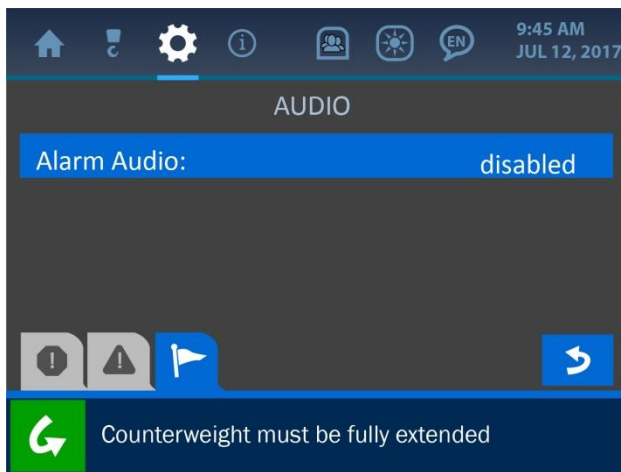

Settings Menu:

- **Locks:** The Locks Menu offers options for restricting operators from accessing various parts of the system.

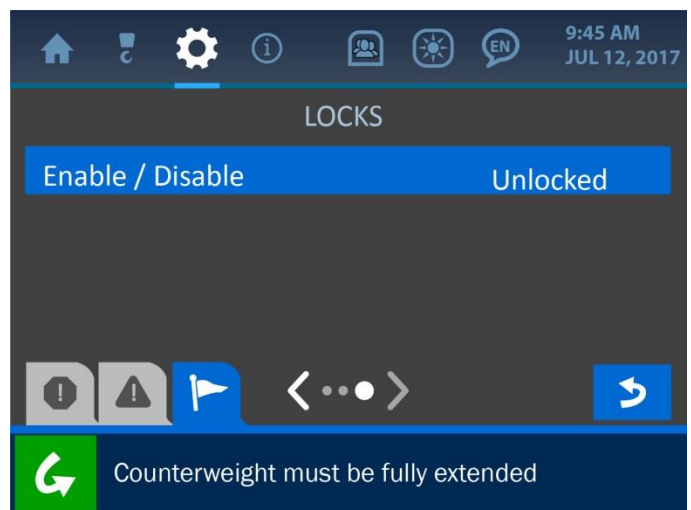
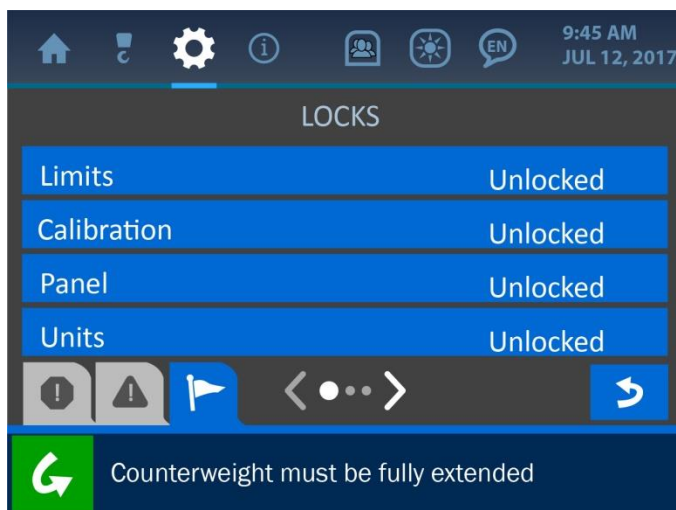

Permission Menu:

- **Setup PIN Code:** This screen is used to set optional user access codes, in order to customize and track each operator's access to the system. First, enable the feature by pressing the Enable Banner Button, then press the 'Set PIN Code Numbers' button to enter the codes themselves.

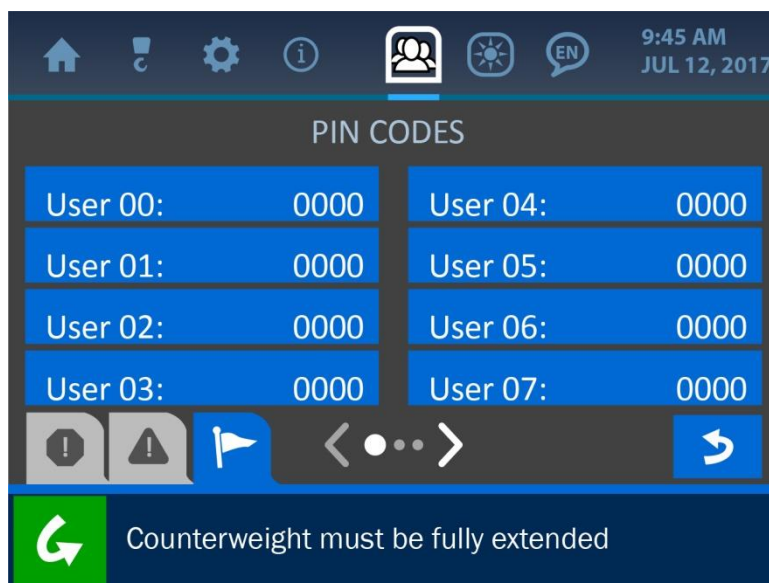
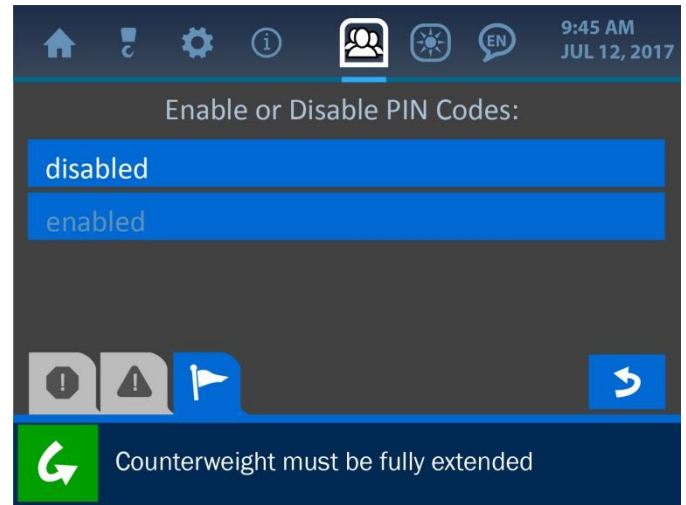
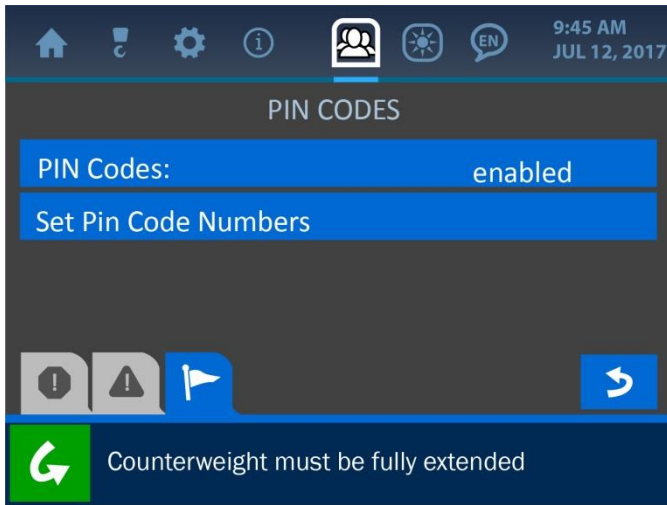

- **Change Supervisor Code:** Customize or change the Supervisor Code from this screen.

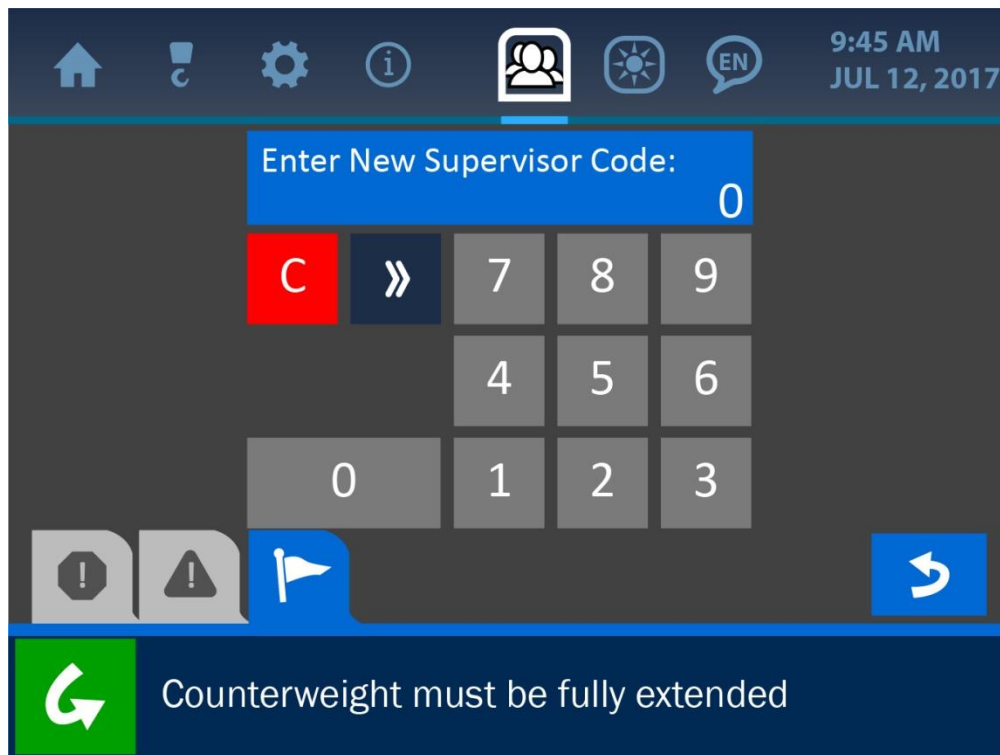

NOTE: See 'The User Interface' section of this manual for more information on The Value Entry Screen.

8. The LCD Brightness and Audio Menu

The LCD Brightness and Audio Screen is symbolized by the 'sun' icon at the top of the display, and can be accessed by pressing the screen directly overtop this icon. Use this menu to adjust the screen's brightness and the system sound for optimal display and performance. Press directly overtop the percentage bars in the center of the screen, or press the increment / decrement buttons on either side of the bars to fine tune the adjustment of either parameter.



8. The Language Menu

The Language Menu is symbolized by the figure icon at the top of the display. Although this icon appears on the display in line with the other active menu options in the system, the language menu has yet to be integrated for functionality. The mention of it in this manual is strictly for clarification purposes.

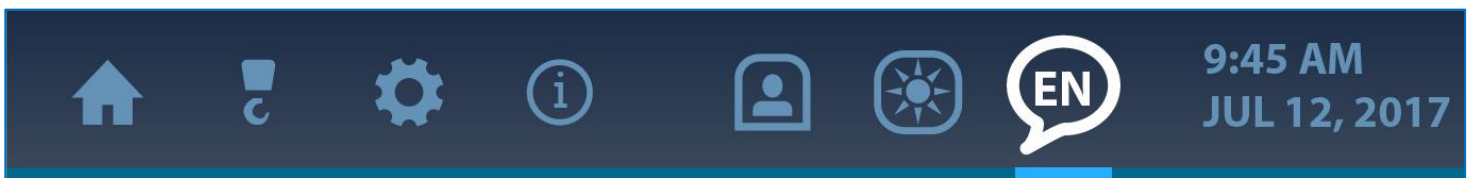

9. The Time and Date Menu

Setting the correct time and date for the system is important for the accuracy of data logs, in case certain job information must be recalled or a machine needs to be serviced. The clock is backed up by a separate battery contained within the panel, eliminating the need to set this parameter each time the panel is powered off. The Time and Date Screen is shown and described below.

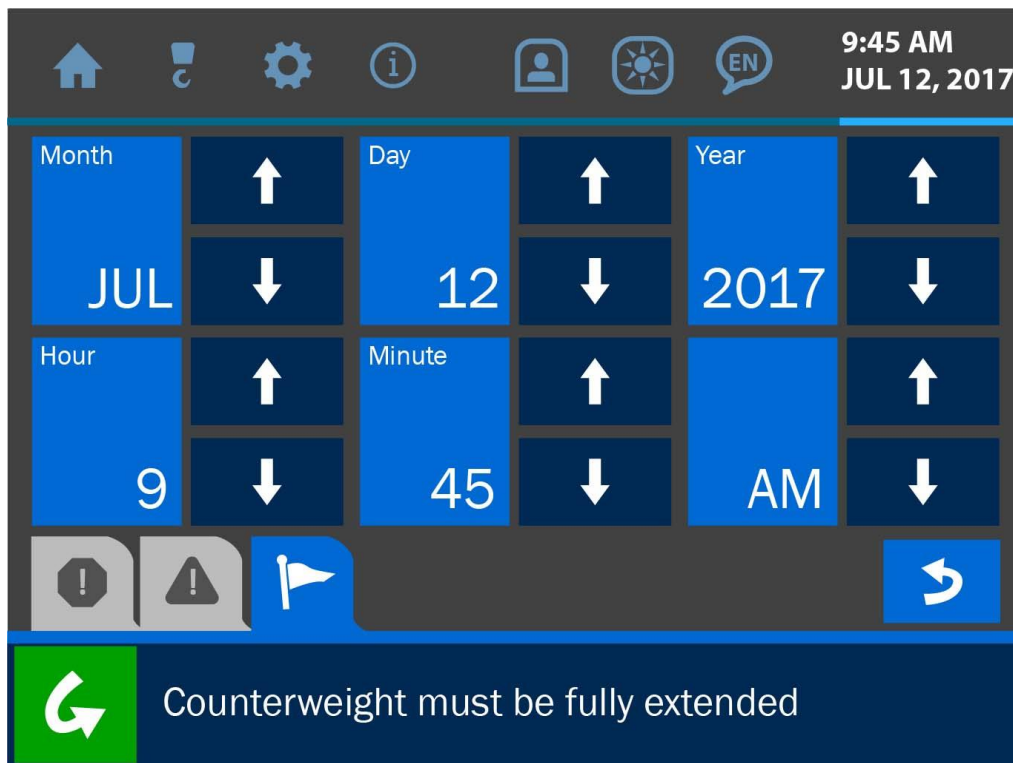

To change the date and time currently displayed, clear the display by pressing the (red) 'Clear' button. Enter the proper value via the keypad, according to this format: year – month – day – hour - minute. Once the display is correct, press the (green) 'Accept' button to save the change and return to the previous screen. **NOTE: See 'The User Interface' section of this manual for more information on the Value Entry Screen.**

10. Troubleshooting

The Cranesmart System performs self-checks for system errors, exceeded limits and any equipment malfunctions. This section illustrates and briefly describes some examples of this.

10.1. Alarm and Warning Screens

The system will notify the operator of any unsafe condition via the built in audible and visual alarms. A loud beep will sound from the display panel speaker, and an associate screen will show what error or unsafe condition has arisen. The alarms may be bypassed using the Bypass Button, located in the lower left corner of the display, which will silence the speaker for 30 seconds. However, the alarm state will persist until the error causing the alarm is corrected.

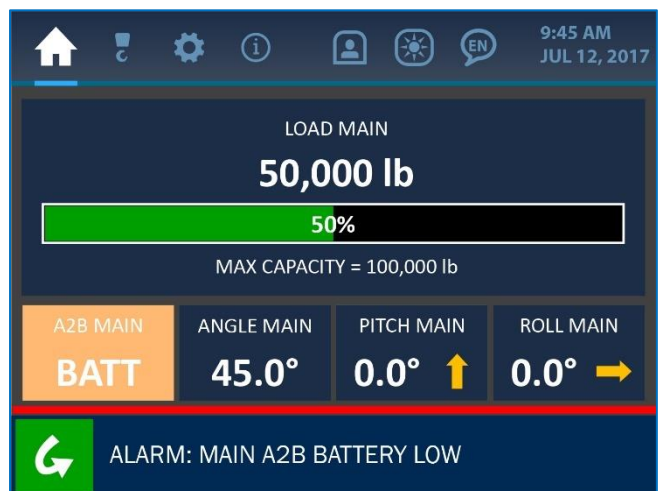
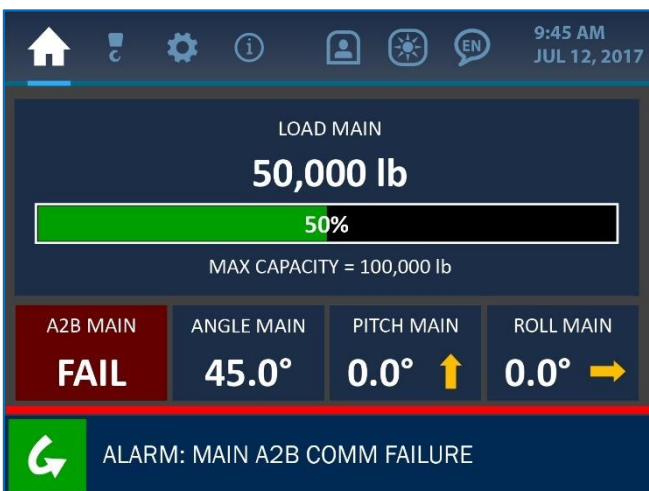
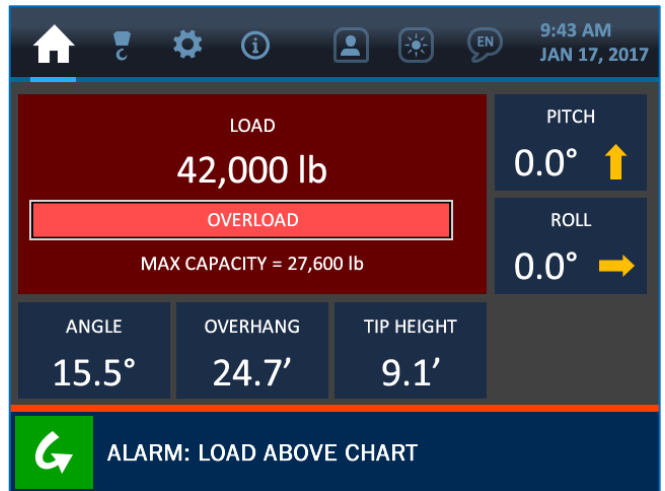
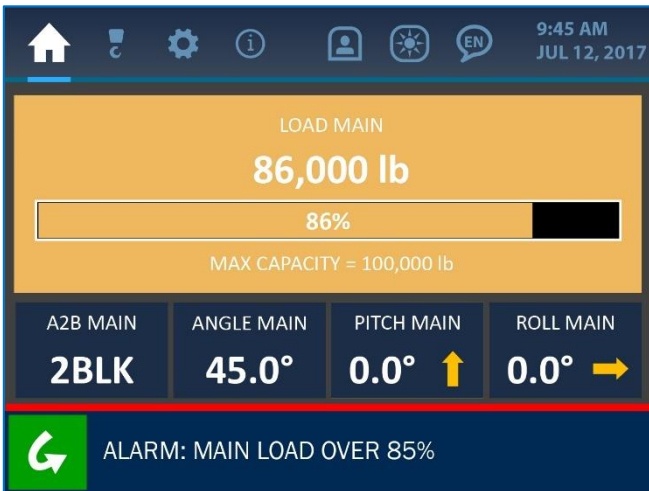

NOTE: Alarms will normally sound while the system components are being installed, and until there is a clear line of sight between the transducers and display panel. If alarms still sound after the components are properly installed, check the Transducer Stats Screen via the Information Menu to ensure a clear signal is being received from all components. If an alarm still persists, please contact the Cranesmart service department at: (780) 437-2986.

10.2. Replacing a Transducer Battery

Before replacing the batteries, call the Cranesmart Systems service department at (780) 437-2986, with the system serial number ready. The serial number can be found on the display panel or any transducer. Once it has been verified that a faulty battery is causing the error, follow the steps below.

Tools and Equipment needed for battery replacement:

- (1) battery replacement kit (obtain a free battery replacement kit from Cranesmart Systems).
The kit contains:
 - (1) 3.6 volt Lithium Ion D-cell battery
 - (1) 1/8" Allen key
 (Alternatively, a 3.6V lithium battery may be purchased from a battery supplier.)

NOTE: If it is humid, raining or snowing – DO NOT OPEN THE TRANSMITTER. Remove the transmitter and perform the battery replacement indoor or undercover.

To Replace the Battery:

1. Remove the cap screw from the battery compartment lid and remove the lid.
2. Remove the battery from the holder.
3. Insert the new battery according to the battery picture on the base of the battery clip.
4. Secure the lid.

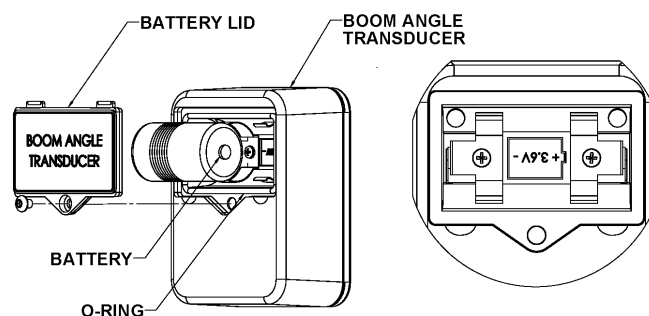

10.3. Replacing a Load Cell Battery

The display panel will indicate a low battery for approximately 3 weeks before the battery fails.

Before replacing batteries, please call the service department at (888) 562-3222 or (780) 437-2986 and have the serial number of the system being serviced readily available. The serial number can be found on the display panel or the load cell itself.

Tools and equipment for battery replacement:

- (1) 3.6 volt lithium ion D-cell battery
- (2) O-rings (one for a 7.5/15/25K load cell, one for a 40K and larger load cell)
- (1) 6g packet of silicone grease (Dow Corning 111 or similar)
- (1) 5/32" Allen key
- (2) battery cover gaskets (one for a 7.5/15/25K load cell, one for a 40K and larger load cell)
- (1) tube of RTV silicone sealant (Dow Corning 734 or similar)

These parts are designed for use with the older gasket sealed load cells and **are not to be used** with o-ring sealed load cells.

NOTES:

- ***A 3.6V Lithium battery can be purchased from a local battery store for use with the load cell. Use the existing system battery for size matching.***
- ***If purchasing a new battery, the o-ring will need to be reused. Use grease as per the instructions below, when installing the o-ring.***

Locate the four exposed hex bolts on the battery compartment side of the load cell. The holes that are filled with silicone indicate the transmitter side of the load cell. Do not open this side – it has no user serviceable parts, and **the warranty will be void if the transmitter electronics section has been opened.**

1. Remove the load cell from the crane.
2. Use the Allen key to remove the four hex bolts.
3. Remove the battery from clip (be careful not to break the red polarisation tab).
4. Install the new battery, (positive to red polarisation tab).
5. Remove and discard the old o-ring from the aluminum plate.
6. Grease the proper replacement o-ring, using a portion of the silicone grease supplied with the kit.
7. Install the new, greased o-ring into the groove on the aluminum plate. Apply the remaining grease liberally, covering the o-ring and groove. **As mentioned above, Do Not use the RTV silicone sealant – it is for the older gasket style load cell.**
8. Carefully place the plastic cover over the battery pack, so as not to pinch the battery wires.
9. Replace the screws and fully tighten the hex bolts. Some grease may squeeze out depending on the amount that was applied.
10. Clean off any excess grease.
11. Reinstall the load cell and test its operation.

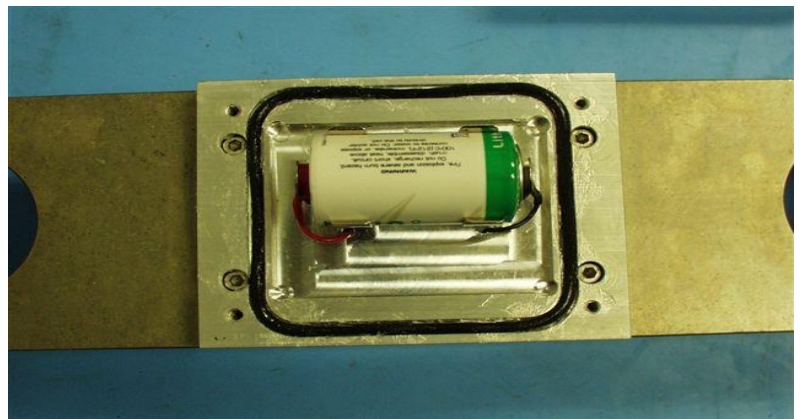
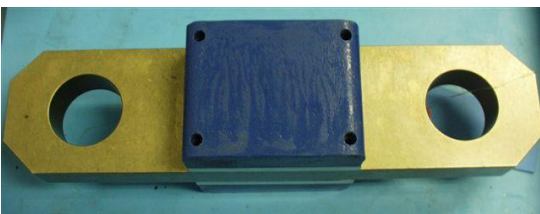

11. Appendix

11.1. Installation Instructions

Guidelines

Read these instructions before beginning installation.

If the power available is not 12 - 24 (28VDC Maximum) Cranesmart Systems can supply the necessary converters. Please call our sales department at (888) 562-3222 or (780) 437-2986.

- Have the necessary tools available.
- Mount the transducers - load cell, angle transducer, A2B switch, etc.
- Mount the panel, alarm hub and antenna.
- Test the system.

Tools Required

- Man basket (if the boom cannot be lowered) – to reach the boom, rooster sheave and/or jib.
- Pliers – for removing and bending cotter pins.
- Electric drill with drill bits.
- Welder – for attaching weld plate to boom/jib tips, if installing A2B or angle systems (not required for load cell installation).
- Wire crimping tools – for the display panel power and ground connections.
- Screwdrivers and/or socket set.
- Anti-seize compound for bolts and threaded pins to ensure the components can be disassembled and/or removed if necessary.

11.2. Load Cell Link Installation A

(Male/Female Load Cell Installation – 7.5K/15K/25K)

1. Pin the blue (main) load cell between the wire rope socket (becket) and the dead end on the main boom of the crane.
2. Pin the yellow load cell (Aux 1) between the wire rope socket (becket) and the headache ball or the auxiliary sheave (rooster) on the crane's boom tip. (Orange is for the Aux. 2 winch, if applicable.)

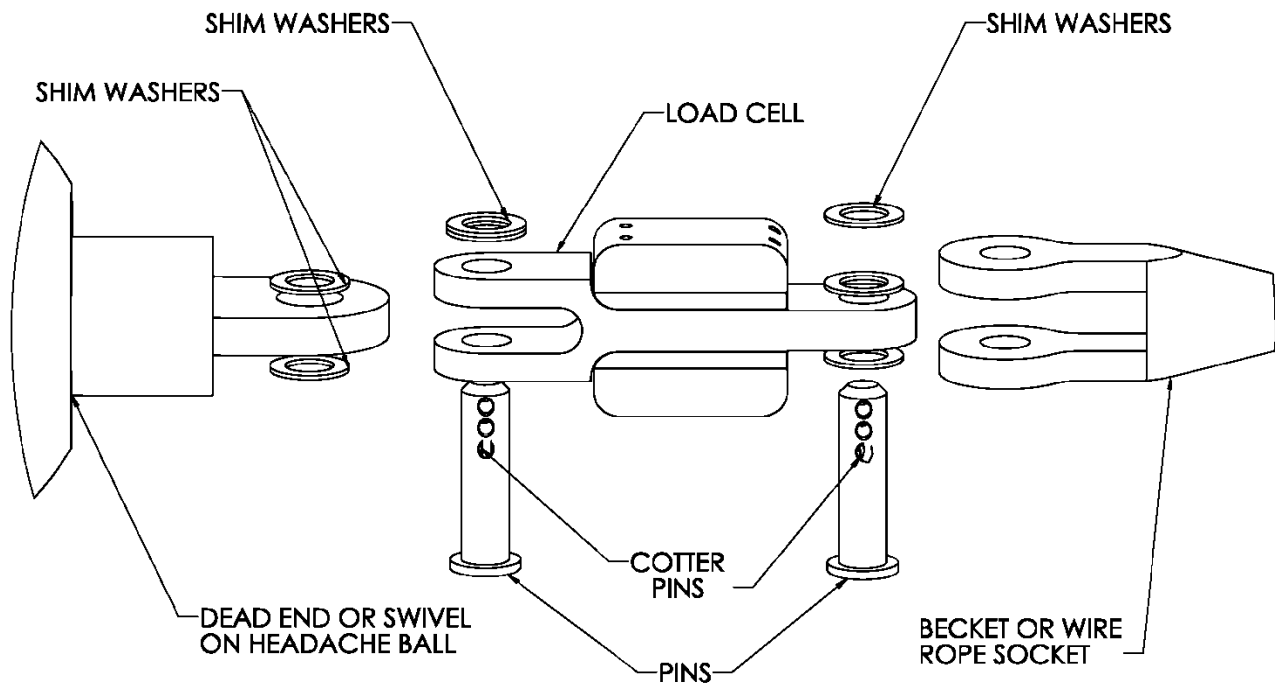

11.3. Load Cell Link Installation B

(Male/Female 7.5K/15K/25K Load Cell Link Placement Dead-End for Multiple Parts-Of-Line)

NOTE: Ensure the load cell does not contact the boom or rigging at any angle when pinned in place.

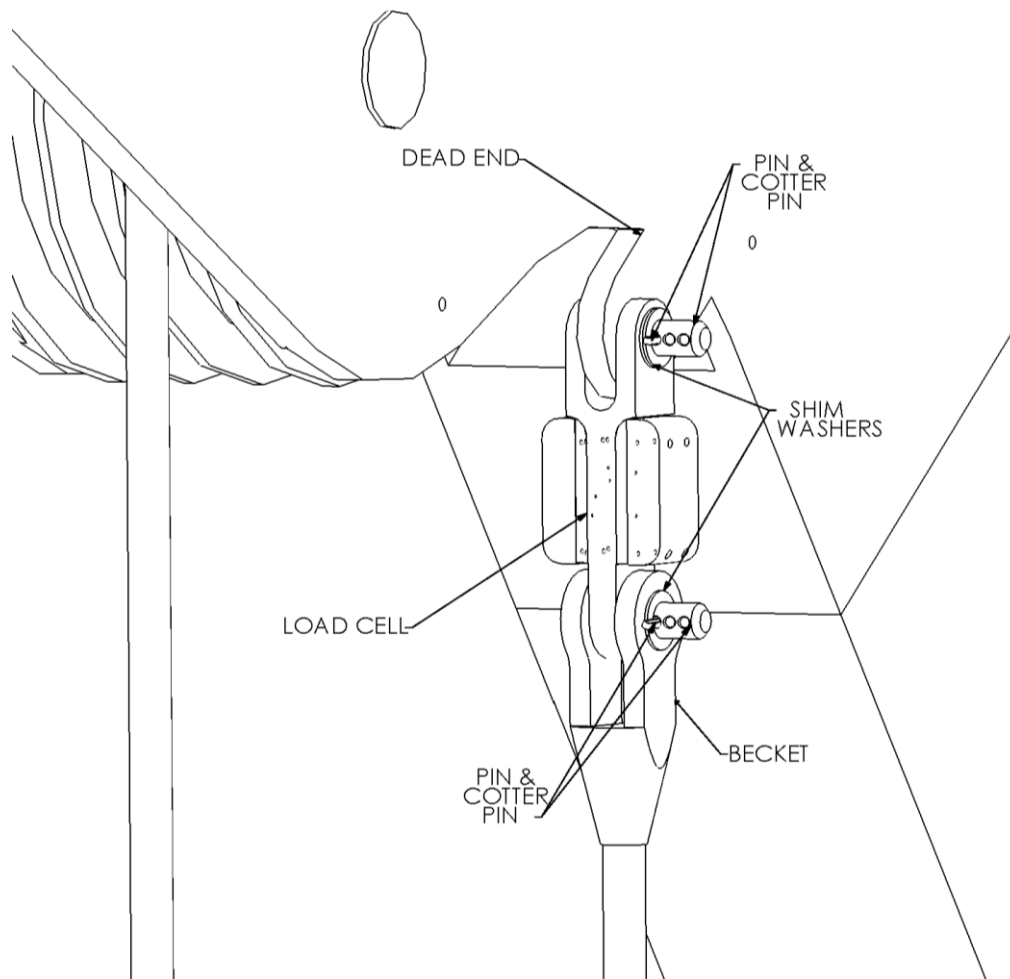

11.4. Load Cell Link Installation C

(Male/Female 7.5K/15K/25K Load Cell Link Placement on Headache Ball for Single Part-Of-Line)

Pin the load cell link between the wire rope (wedge) socket and the 'headache ball' or hook block as illustrated below.

The system is factory calibrated. To address any questions, please call the Cranesmart Systems sales department at (780) 437-2986.

NOTE: Custom links are available to help fit the load cell on the ball, if necessary.

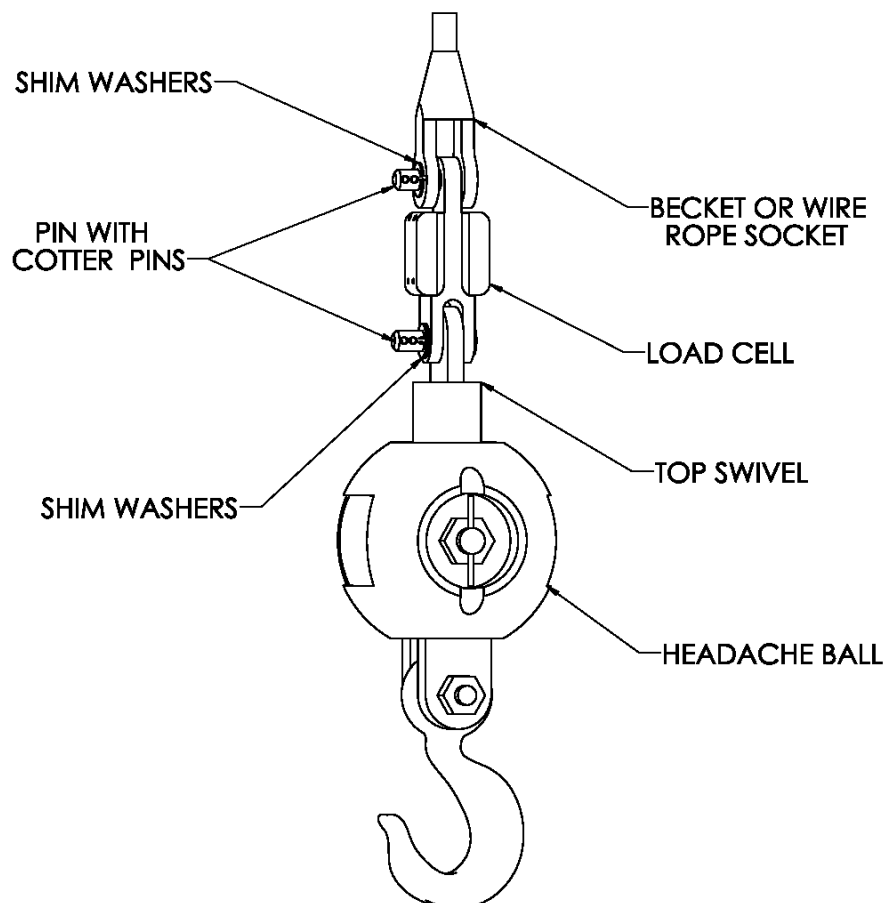

11.5. Load Cell Link Installation D

(Male/Male 40K/50K/80K Flat Link Load Cell Link Installation)

Sandwich Link Stabilization Pin – Male/Male flat link load cells only

The sandwich link stabilization pin prevents the sandwich link from folding against, and damaging the load cell when the headache ball or hook block is laid on the ground or during a two-blocking. Ensure that this pin is securely in place. Also ensure that the locking threaded centre pin and the stabilization pins are located in place as illustrated below.

NOTE: Ensure the load cell does not contact the boom or rigging at any angle when pinned in place.

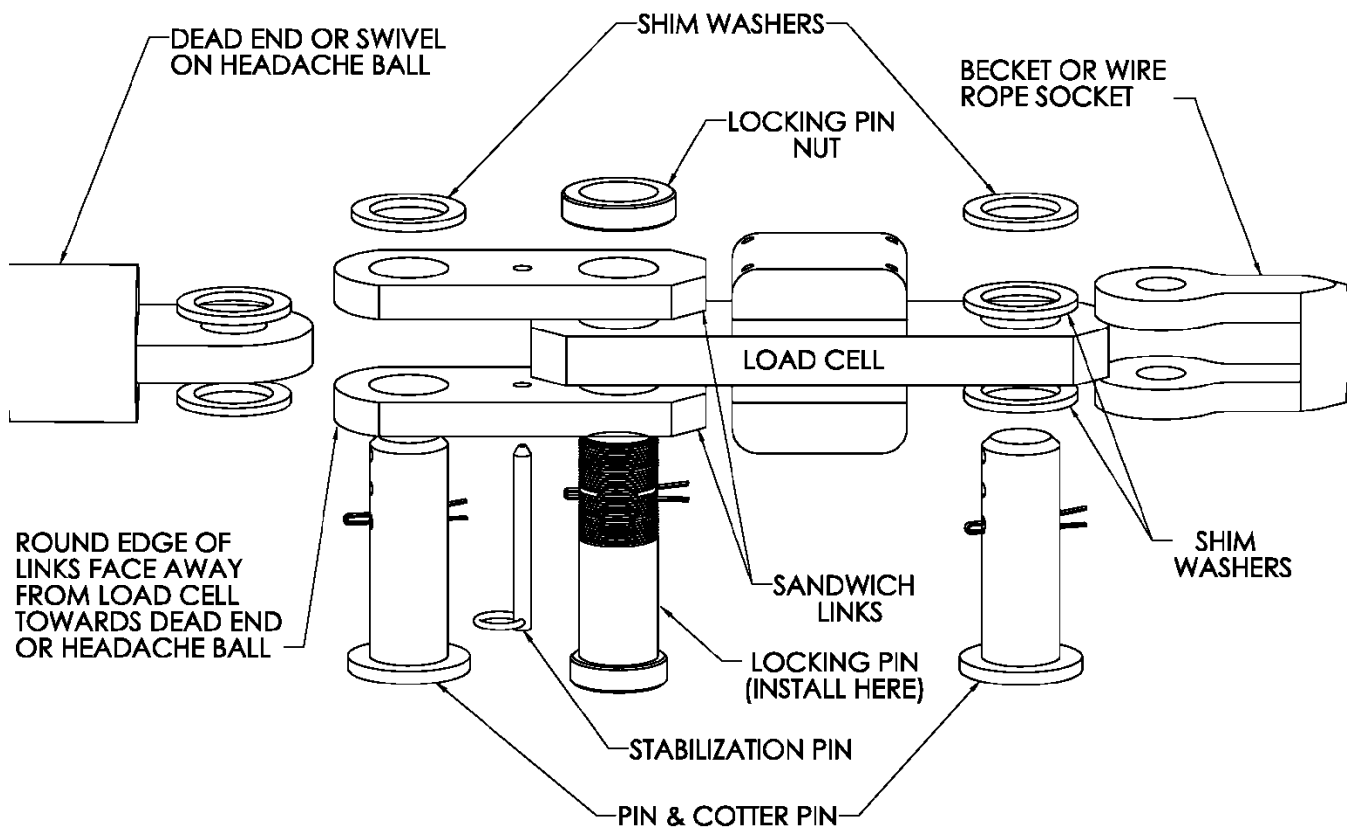

11.6. Load Cell Link Installation E

(Male/Male 40K/50K/80K Load Cell Link Placement on Boom Tip Dead-End for Multiple Parts-Of-Line)

The drawings below show the standard sandwich link installation and the optional 24" long sandwich link installation. Use the sandwich links to pin the load cell link between the wire rope socket (becket) and the dead-end boom tip as illustrated below. Place the locking threaded centre pin (important) and the stabilization pin as illustrated below.

NOTE: Each system is factory calibrated. Please call the Cranesmart Systems sales department at (780) 437-2986 for assistance and/or further information.

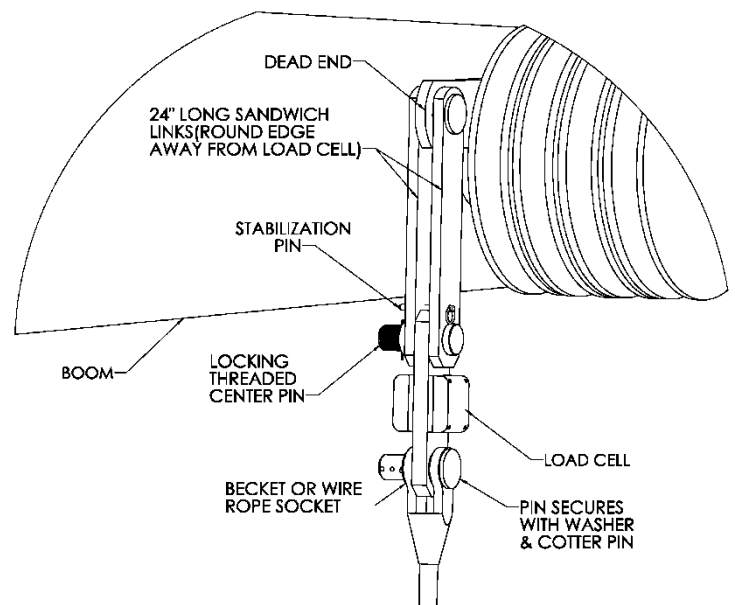
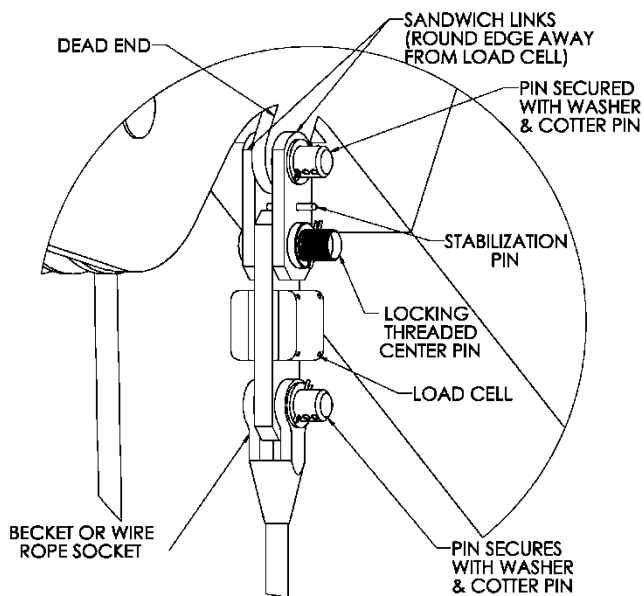

11.7. Load Cell Link Installation F

(Male/Male 40K/50K/80K Load Cell Link Placement on Headache Ball for Single Part-Of-Line)

Pin the load cell link between the wire rope (wedge) socket and the 'headache ball' or hook block as illustrated below. Place the locking threaded centre pin and the stabilization pin as illustrated below.

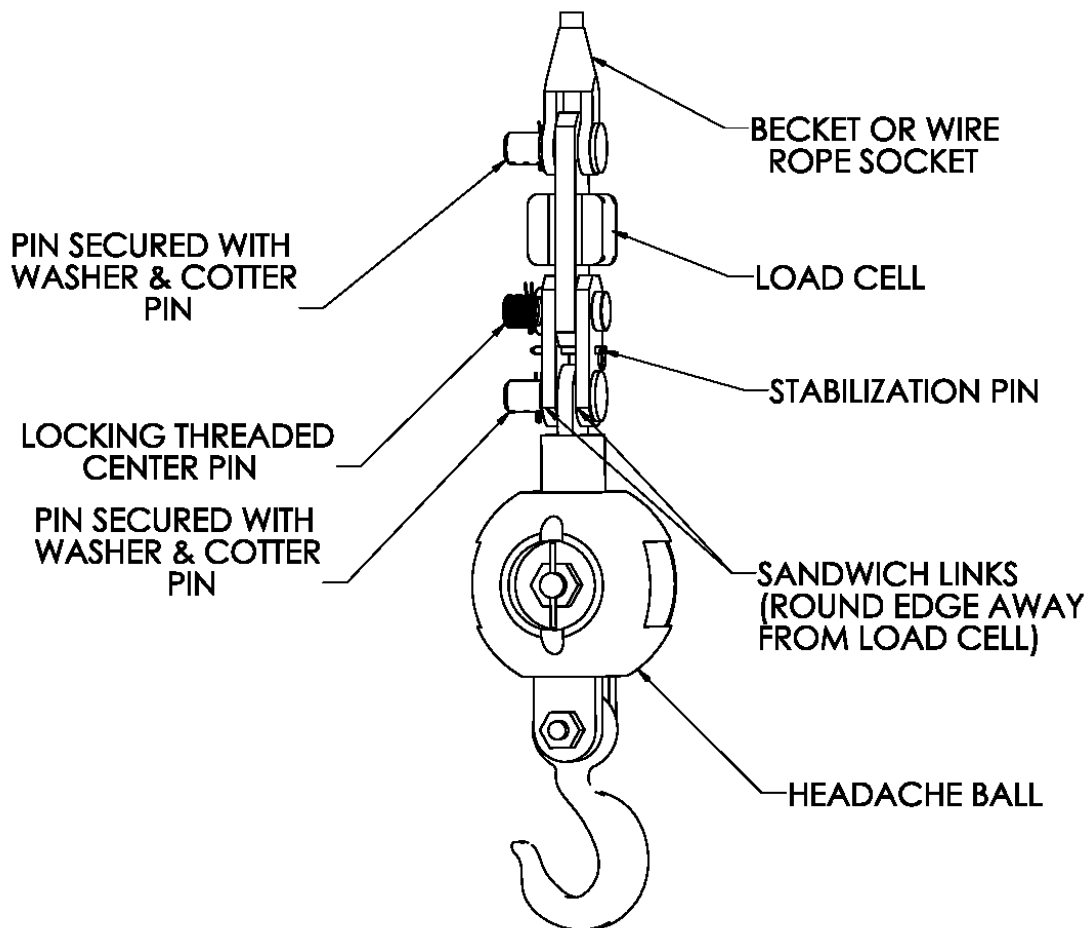

11.8. Radio Linerider Installation

The linerider installation will vary, depending on the type of crane boom it's being installed on. Follow the instructions below for hydraulic or lattice style boom installation.

The linerider is attached to a swing arm mounting bracket (included with kit) as shown in the illustration. The swing arm assembly has four joints:

1. Vertical movement at the attachment point to the linerider
2. Horizontal movement of the swing arm
3. Vertical movement of the swing arm
4. Swivels horizontally around the mounting bolt

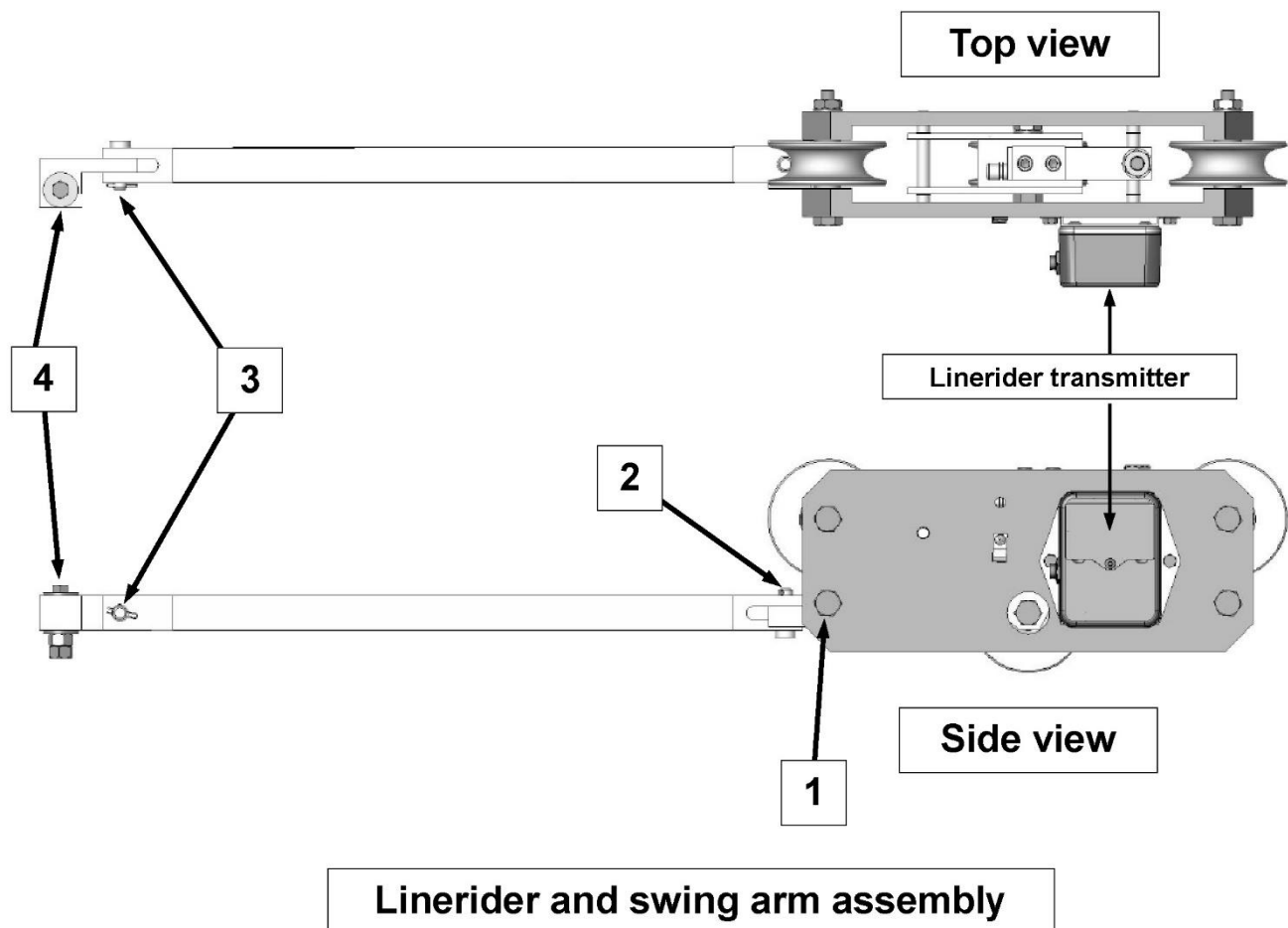

11.9. Hydraulic Boom Linerider Installation

NOTE: The linerider should be located on the top of the boom and as close to the dead-end section of the boom tip as possible (see the illustration below).

1. Affix the bolt at the tip of the base section (dead section) of the hydraulic boom as illustrated to the right. Select a location so that the swing arm angle with respect to the boom will not exceed 30° during normal operation of the crane. The linerider should be located on the top of the boom and as close to the tip of the base (or non-moving) section as possible.
2. Attach the swing arm to the bolt.
3. Run the hoist line through the linerider (see the section *Installing the Wire Rope Through the Linerider* of this manual).
4. Check to ensure that the linerider has freedom of movement from side to side.

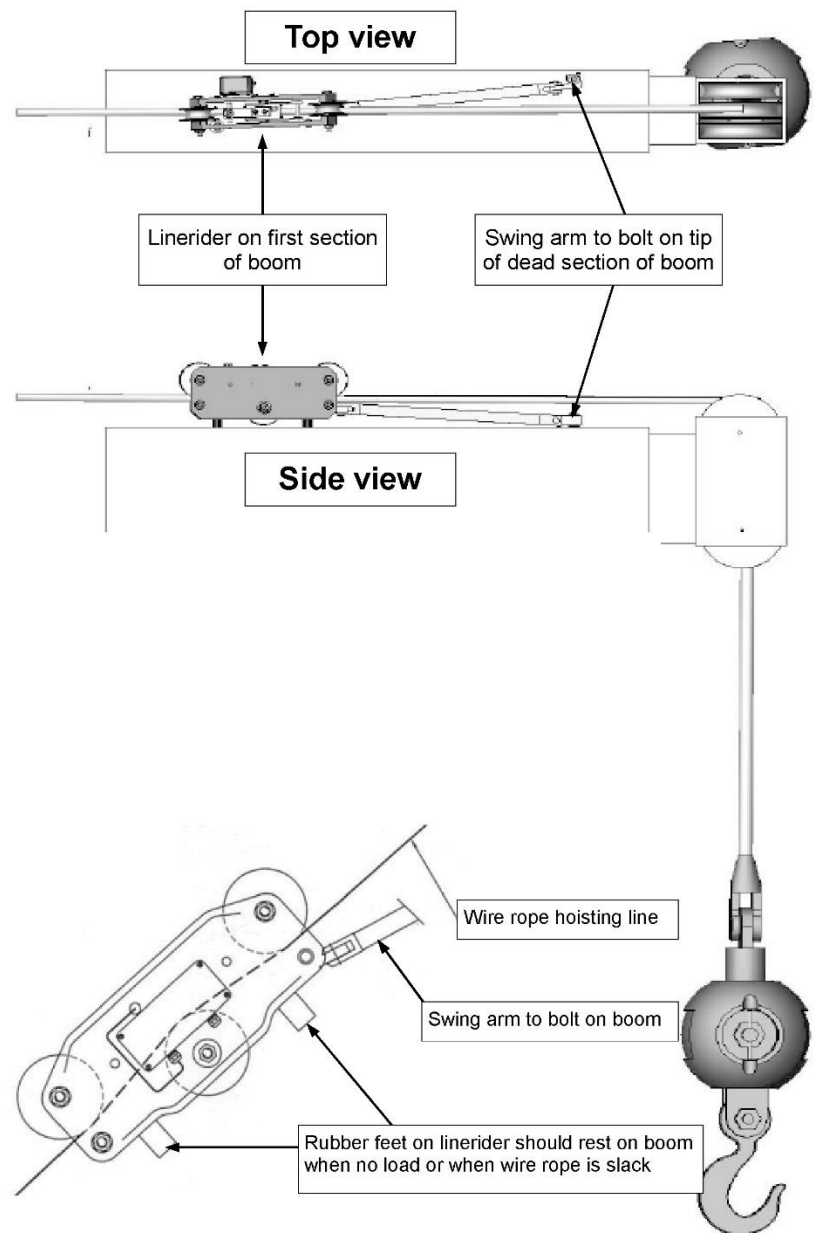

11.10. Lattice Boom Linerider Installation

NOTE: The linerider should be located on the top of the boom and as close to the boom tip as possible.

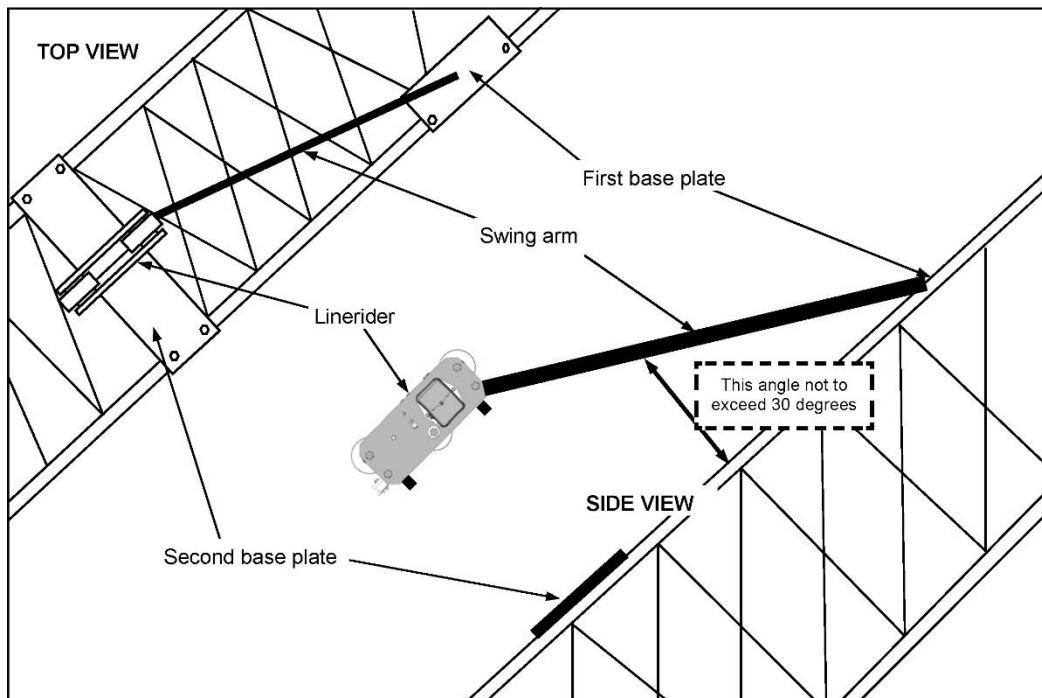

1. Select a location that the swing arm angle with respect to the boom will not exceed 30°. The linerider should be mounted as close to the lattice boom tip as possible.
2. Construct two base plates. The size of the base plates will be specific to the lattice structure and the plate location.
3. The first base plate will be attached to the boom with the swing arm bolt affixed to the center of the base plate.
4. The second base plate will be attached to the boom so that it supports the linerider when not in use.

5. Affix the swing arm bolt to the center of the first base plate.

6. Affix the first base plate to the selected location on the lattice boom.

7. Attach the swing arm to the bolt.

8. Run the wire rope (hoisting line) through the linerider (see the section *Installing the Wire Rope Through the Linerider* of this manual).

9. Ensure freedom of movement from side to side.

10. Attach the second base plate to the boom so the linerider's rubber feet will touch the plate when there is no load (wire rope is slack).

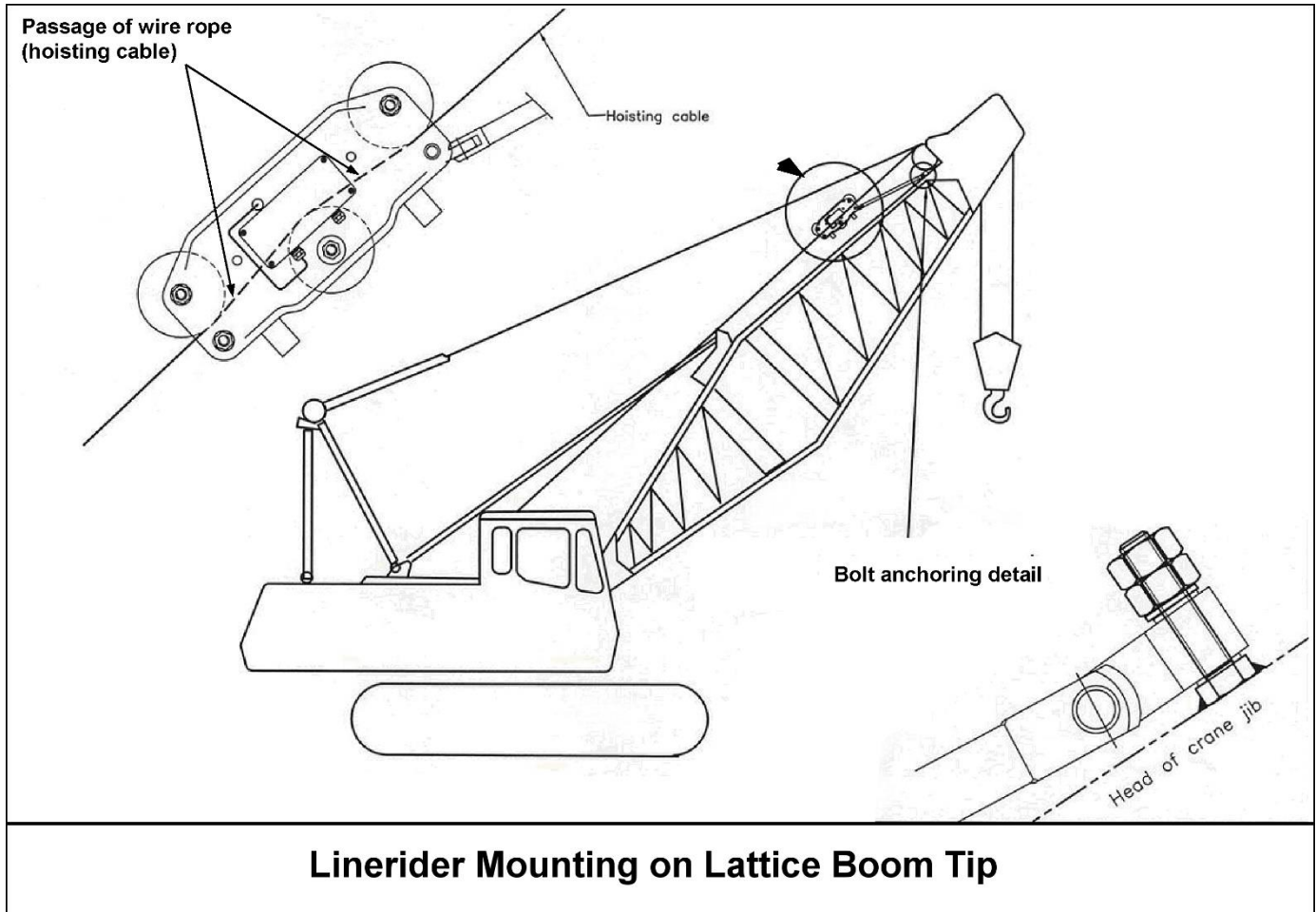

11.11. Installing the Wire Rope Through the Linerider

1. With the linerider positioned as illustrated, remove the free axle (at bottom left of the linerider).
2. Remove the anchoring axle (at bottom right of the linerider).
3. Remove the anchor component with sleeve.
4. Remove the measurement pulley axle (at the left center of the linerider).

5. Remove the pulley with its sleeve.
6. Pass and position the wire rope (hoisting cable) as illustrated.
7. Reassemble the linerider in reverse order to the above disassembly steps.

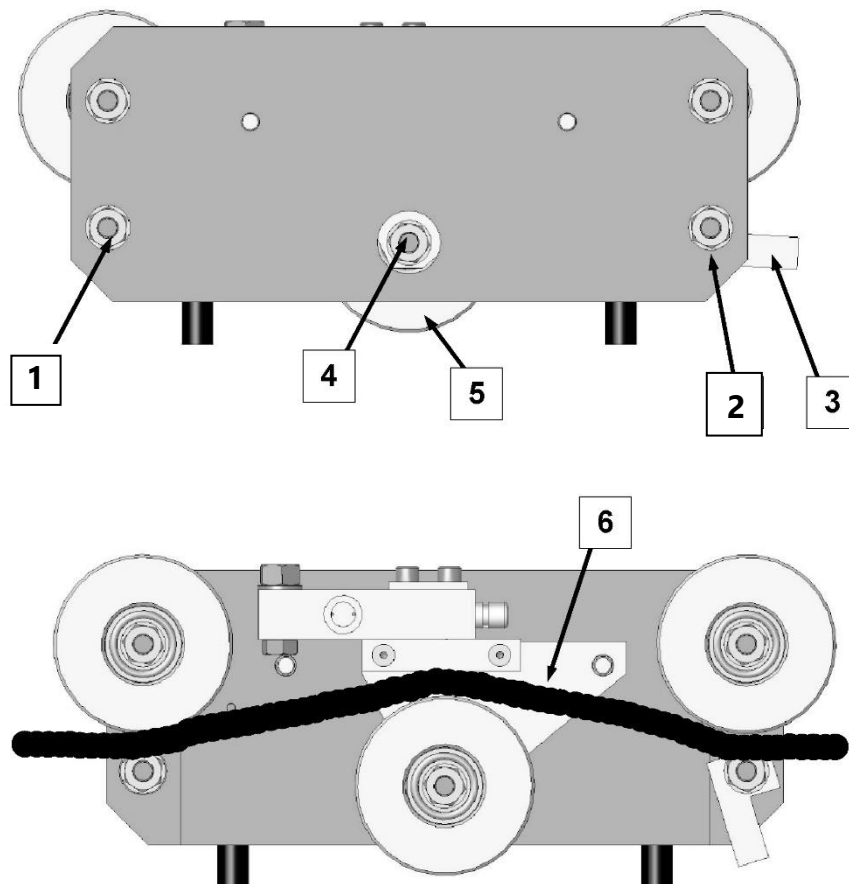

11.12. Load Pin Installation

To Install the Load Pin:

1. **Remove the existing pin**
2. **Installation**

Use the shim washers provided to center the pin on the dead end and to remove as much side to side motion as possible. If you have a Shackle Load Pin use the shackle

provided with the load pin. It has been fitted with bushings and is critical to the accuracy of the load pin.

The transducer box contains sensitive electronics. DO NOT USE A HAMMER or any object to strike the pin into position during the installation procedure.

Apply grease to the outer contact surfaces of the load pin to reduce friction especially if the pin uses a centering bushing. Check and grease the pin regularly.

3. **Secure the Load Pin**

The load pin will be secured with either a nut /cotter pin or just a cotter pin. If there is a nut with the pin it should be made hand tight only. DO NOT USE A WRENCH to tighten the nut onto the pin as the torque could affect the calibration of the pin causing inaccurate readings. Always ensure that the threads of the pin and nut are coated with anti-seize grease such as KOPR-KOTETM. Install the cotter pin through the hole in the end of the pin. Use washers to secure the pin in place and keep it from moving side to side as this will affect calibration.

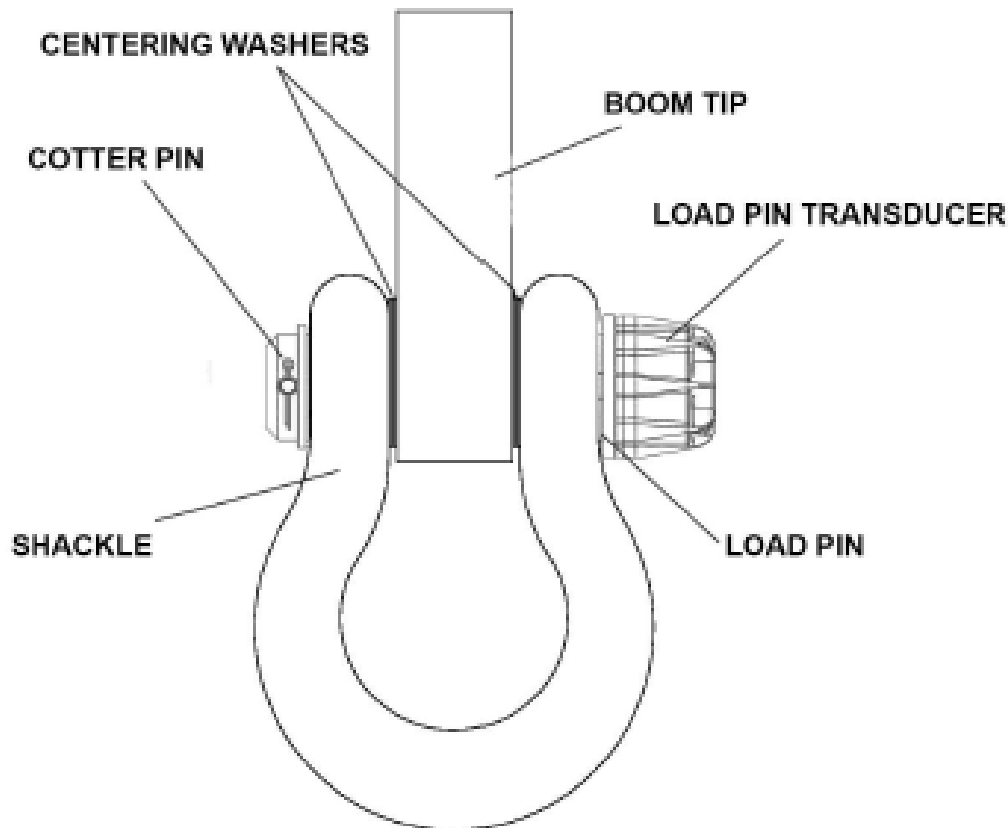

4. **Free Rotation**

Ensure that when the load pin is installed that it will turn without binding or being stopped from rotating through the full 360°. It is important to allow this pin to turn freely to maintain the accuracy of your load pin. If the pin is not rotating freely it can cause inaccurate readings and unexpected forces to be interpreted as load.

5. **Check for Good Signal Strength on the Display Panel**

The Cranesmart system works by receiving radio messages from your load pin transducer box and displaying the load readings on the Cranesmart panel. It is important to keep a good open line of sight between the panel and the load pin transducer box. Follow the signal strength instructions provided in the operation section of the manual.

6. **Verify the Load Pin Calibration**

All of the load pins are factory calibrated but due to small differences in crane boom dead ends the accuracy of the factory calibration on your crane may change slightly. Verify the calibration of the load pin by lifting a certified weight.

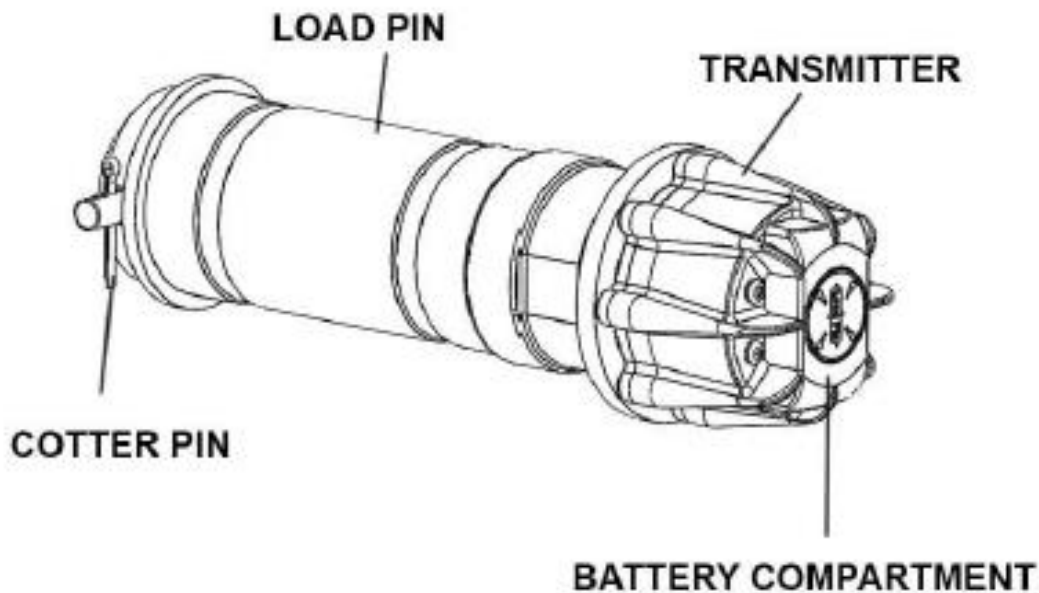

7. Protection and Care for the Load Pin

The transducer box is attached directly to your load pin, so care must be taken to ensure that there will be NO DIRECT IMPACTS made on this side of the pin. Although the case is made of impact resistant plastic, care must be taken during installation and operation of your crane to protect the transducer box from being damaged.

If the blue transmitter case located on the load pin is in danger of receiving damage during normal crane operations please call our service department at (888) 562-3222 or (780) 437-2986 for assistance before starting operations. Because all cranes are not the same there can be various methods for protecting the load pin from impact damage depending on the type of pin and operational use. Do not completely encase the blue transmitter box when protecting it as this will prevent radio communication.

11.13. Anti-2-Block Installation

The switch is designed to swivel and pivot to track with the wire rope in relation to the boom angle.

1. Weld the weld bar to the crane. Ensure the switch is mounted directly above the dead-end or the slowest speed line. The weld bar can be welded directly to the crane or to an existing Cranesmart weld plate. (Both ends of the weld bar are identical).
2. Ensure that the mounted A2B switch will have an unobstructed line-of-sight to the receiver panel antenna. Install the large shoulder bolt into the A2B swing arm.
3. Attach the A2B switch to the bar. (Install the nylon bushing between the bar and the swing arm).
4. Attach the two-piece counterweight to the dead-end line or the slowest speed line.
5. Use the shackle (bottom of A2B switch) to install the chain to the A2B switch.
6. Counterweight Safety Cable: This Safety Cable is used to secure the counterweight so that it will not fall down the wire rope in the case of severe damage to the A2B. See drawing for proper installation.

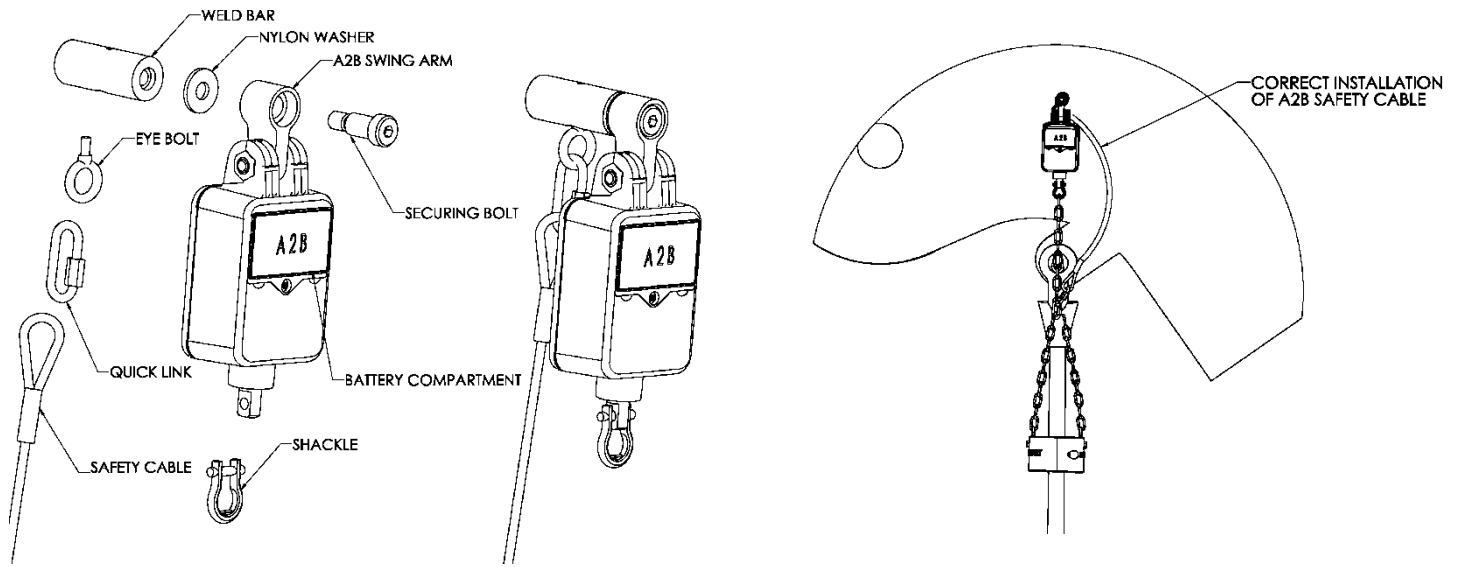

NOTE: Ensure the A2B switch can move freely without contacting the boom, the sheaves, bracing struts or any other equipment such as a swing away jib extension. The Eyebolt on the weld bar is used with the red clip for storage and transportation on mobile cranes. When transporting the crane, it is advised that the weight is hung using this method, in order to remove tension from the counterweight chain.

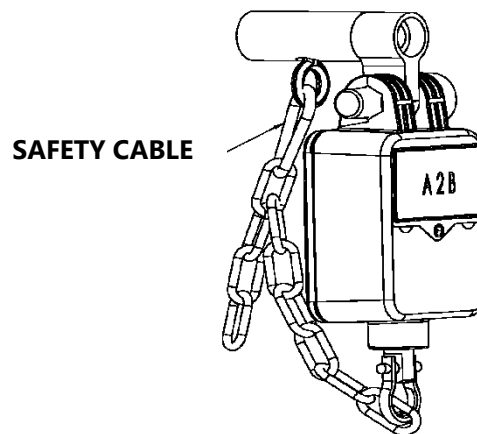

1. Attach the counterweight chain to the bottom of the A2B transmitter using the shackle supplied.
2. Assemble the counterweight around the cable, as shown in the illustration.
3. Bolt the two counterweight halves together using the cap screws. The cap screws are coated with oil but it is suggested that anti-seize compound be used on the bolts to allow for easy removal.

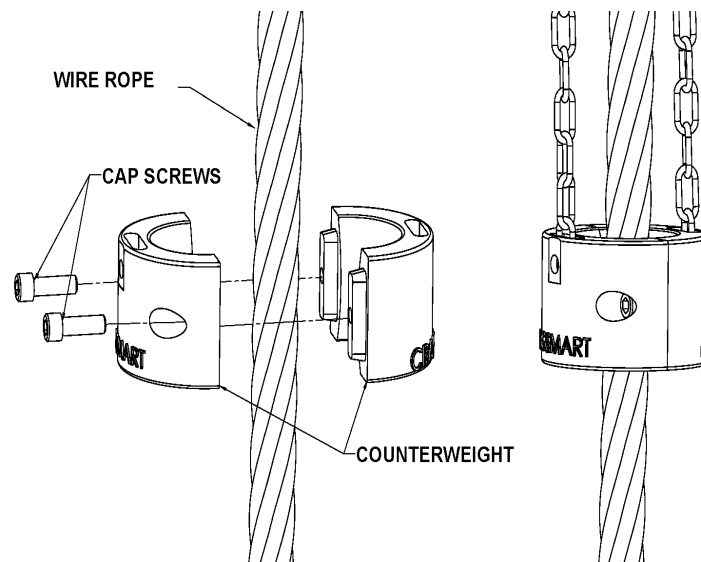

11.14. Boom Angle Transducer Installation

The boom angle transducer can be mounted on either side of the boom. The transducer cannot be installed on the top or bottom of the boom and must be installed in the orientation shown in the diagram below. Do not weld permanently before testing in case adjustments are needed.

1. Remove the weld plate from the angle transducer.
2. Align and mark the installation position. Position the transducer to be parallel (level) with the boom line.
3. Tack weld the weld plate before testing the system.
4. Mount the transducer to the weld plate.
5. Verify operation
6. Raise the boom to a minimum angle of 45° and return it to level. (This will set the transducer for the proper side of the boom before calibration).
7. Remove the transducer to finalize the welding

8. Repeat steps 4-6

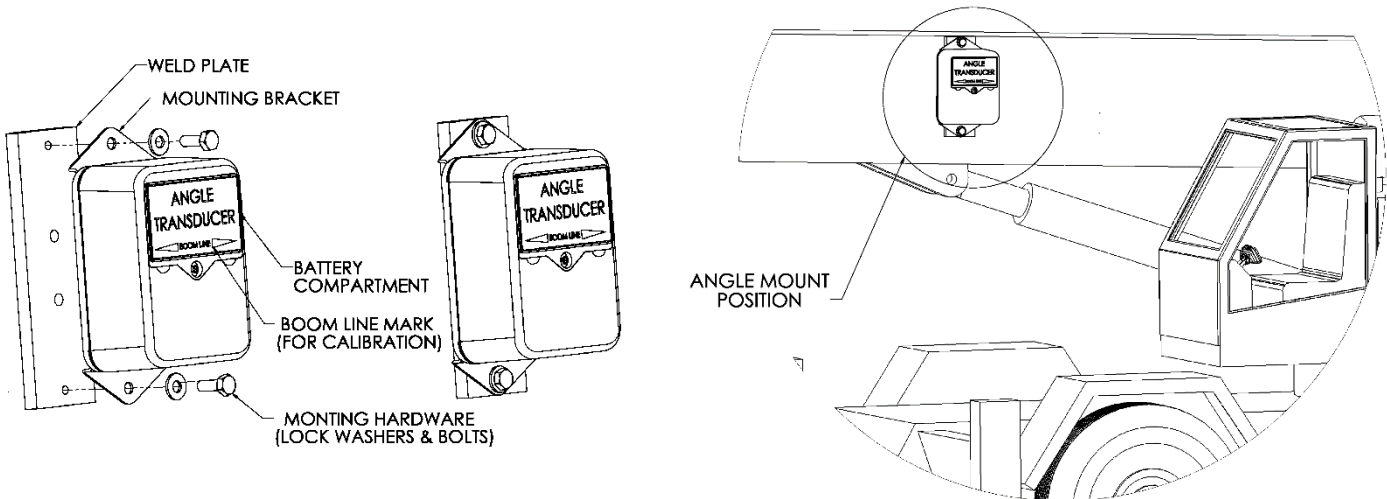

11.15. Windspeed Transducer Installation

The wind speed transducer is designed to swivel so that it is always in an upright, vertical position, regardless of the boom angle.

Tools Required

- 5/16" hex key (included)
- 3/16" hex key (included)
- Welder

Wind Speed Installation Procedure

1. Remove the shoulder bolt from the weld bar and swivel mount plate.

2. Tack weld the weld bar to the crane. The weld bar can be welded directly to the crane or to an existing Cranesmart weld plate. (Both ends of the weld bar are identical).
3. Attach the wind speed swivel mount plate to the weld bar using the shoulder bolt and washer. Use a 5/16" hex key to tighten the bolt.
4. Attach the wind speed transducer to the swivel mount plate using the provided hex key bolts and lock washers. Use a 3/16" hex key to tighten all bolts.
5. Ensure that there is enough clearance for the wind speed transducer to swing freely. Finish welding the weld bar to the crane.

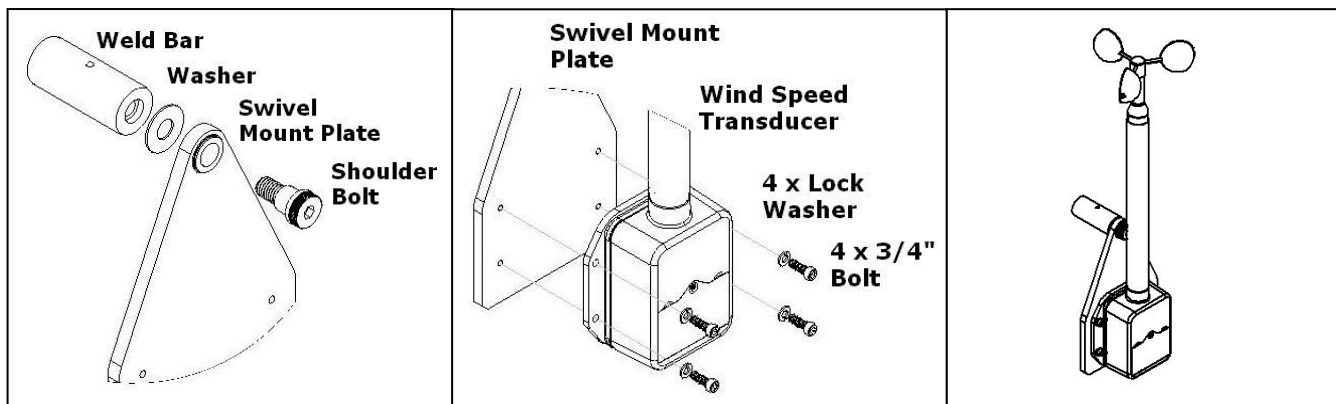

11.16. Level Transducer Installation Type A (Measuring Machine Tilt (Roll))

This installation is typically used in marine applications where the crane is on a ship or a barge and it allows the user to observe actual tilt based on the direction of the boom.

1. The level transducer should have a clear line of sight to the Cranesmart system's antenna and be kept free of all obstructions.
2. The level transducer must be mounted onto a part of the crane that rotates along with the boom, but does not change with the boom angle. The label must be facing up and the directional arrow should point along the boom towards the tip.
3. Make sure that the transducer is not mounted in a position where it might be stepped on or in a position where it may suffer impact damage. Possible mounting locations are on top of the turret or on the operator's cab if it rotates with the boom.
4. The mounting position needs to be stable during operation as vibration may cause the unit to jitter.

5. The transducer should be made as level as possible but it is **NOT** critical that it be perfectly level, as the unit can be calibrated after installation. (See the *Level Calibration* section of this manual).
6. Verify communication with the receiver panel before permanently mounting the transducer (see the *Transducers* section of this manual).
7. The crane **MUST** be level during the calibration process.
8. **DO NOT** weld the weld plate with the level transducer attached.

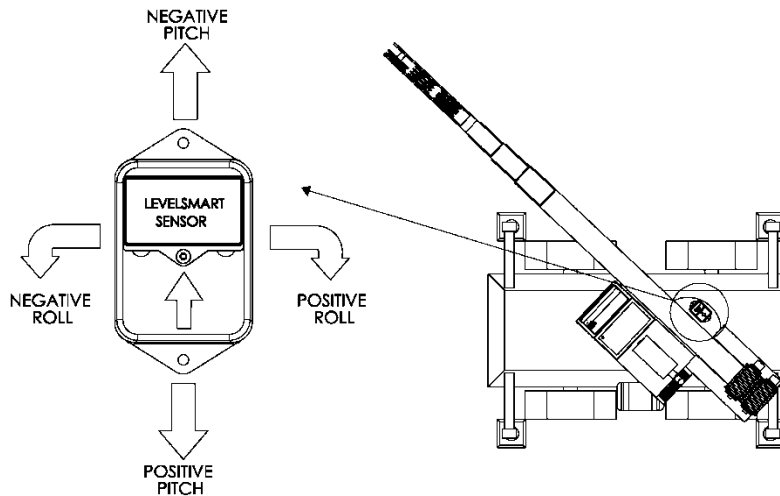

11.17. Level Transducer Installation Type B

(Measuring Grade and Super Elevation / Ship List (Roll) and Trip (Pitch))

This installation should be used for locomotive cranes (grade and super elevation) or ship and barge applications where the user wants the Cranesmart system to indicate if the **ship** is listing (rolling) or trimming (pitching)

1. The level transducer should have a clear line of sight to the Cranesmart system's antenna and be kept free of all obstructions.
2. The transducer can be mounted to the deck (label facing up) or onto a post. The higher the level transducer is from the deck, the better the radio transmission will be.
3. The correct mounting position of the level transducer is critical. The label must be facing up and the directional arrow should point towards the front of the car or ship. Refer to the diagram below.

4. The mounting position needs to be stable during operation as vibration may cause the unit to jitter.
5. The level transducer should be made as level as possible but it is **NOT** critical that it be perfectly level as the unit can be calibrated after installation. (See the *Level Calibration* section of this manual).
6. Verify communication with receiver panel before permanently mounting the transducer (see the *Transducers* section of this manual).
7. The barge deck **MUST** be level during the calibration process.
8. **DO NOT** weld the weld plate with the level transducer attached.

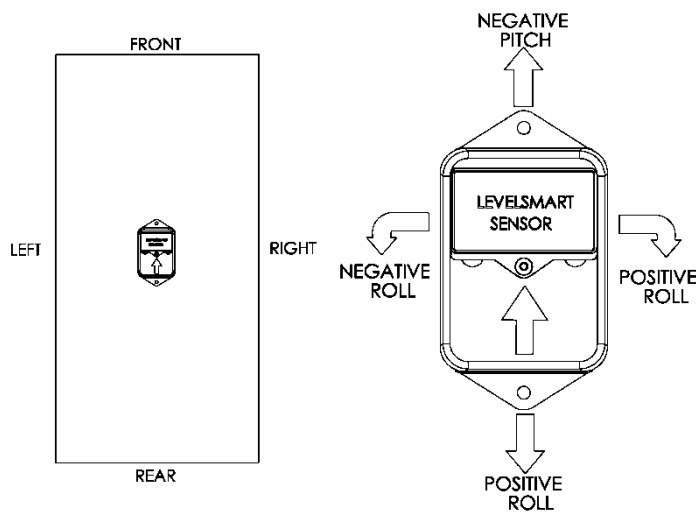

Refer to this table for application terminology

Default	Roll	Pitch
Locomotive Crane	Super Elevation	Grade
Ship/Barge	Listing	Trimming

11.18. Powerline Proximity Sensor Installation

The powerline proximity sensor must be mounted to the highest point and leading edge of the machine, (boom tip for example). The leading side may not be the same as the angle indicator, depending on where the powerlines are located in relation to the boom. For strongest communication, maintain the best line of site between the transducer and the display panel as possible.

1. Align and mark the installation position of the weld bar.
2. Tack weld the weld plate before testing the system. **NOTE: Ensure that transducer is not attached to the weld bar during welding.**



3. Mount the transducer to the weld plate.
4. Adjust the setpoint of the transducer (see the Powerline Calibration section of this manual).

NOTE: This setpoint is field adjustable and must be configured properly for every powerline affecting work.

5. Remove the transducer from the weld bar.
6. Complete the weld and remount the transducer.



11.19. Display Panel Installation

Mounting the Display Panel

1. Mount the display panel to ensure the operator has an unobstructed view.
2. Align the ram mount bracket; mark and drill mounting holes using the mounting bracket as a guide.
3. Attach the bracket using the hardware provided.
4. Install the display panel to the bracket.
5. Mount the ram mount bracket to an appropriate place within the cab, using the 3/8" bolts provided.

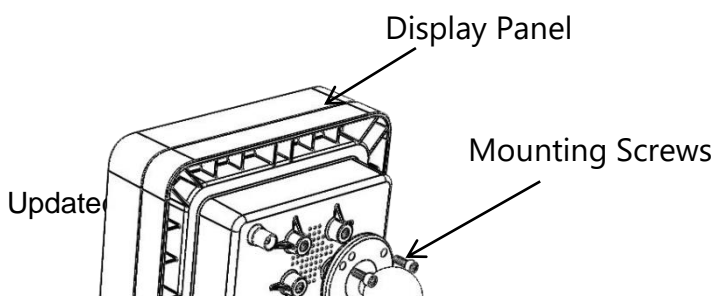
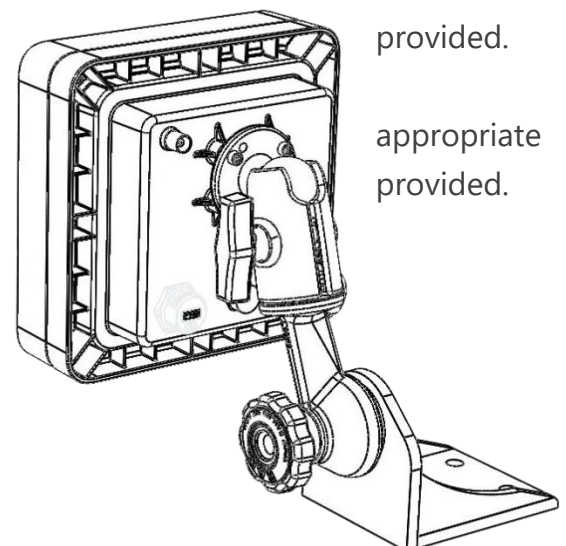

NOTE:

- ***The display panel can pivot horizontally or vertically by changing the position of the mounting bracket.***
- ***The panel should be mounted in the operator's field of view but not obstruct sight during a lift.***
- ***DO NOT PRESSURE WASH THE DISPLAY PANEL OR SUBMERGE IT IN WATER.***

Wiring the Display Panel

Power to the display panel is supplied through the cable included in the kit, which plugs into the back of the panel. Refer to the wiring diagram on the following page.

1. Connect the red wire to a positive 12-24VDC (28VDC Max) terminal.
2. Connect the black wire to a good ground connection on the machine.
3. *(Optional):* Connect the white wire to an optional 'shut off' solenoid or to sound external horns. (Maximum output is 7.5 amps).

NOTES:

- ***Ensure that a continuous 12-24VDC (28VDC max) is available to the panel at all times while the machine is in operation. If the voltage drops below 10.5 VDC the panel will not function.***
- ***When attaching the power cable to the panel, align the plug and gently push it into the receptacle, then slide the plug neck back towards the panel and turn it clockwise half a turn to tighten.***
- ***If the power cable is cut to shorten it for installation, it will be noticed that two extra wires are contained inside the insulation. The purple and blue wires are only used in other applications (for RS485 communication).***

11.20. Alarm Shutoffs (White Wire)

The Cranesmart system will be shipped with a three-conductor wiring harness which consists of a black, a red, and a white wire. The white wire may be used in conjunction with external alarm horns, lights, or shut-offs (if installed).

- When supplying power to the Cranesmart System with +12 VDC, the white wire is normally hot (energized) with a +12 VDC in a non-alarm condition. If the white wire is not to be used for any of the purposes listed above, ensure that its exposed end remains sealed to prevent grounding and damage to the display panel.
- When supplying power to the Cranesmart System with +24 VDC, the white wire is normally hot (energized) with a +24 VDC in a non-alarm condition. If the white wire is not to be used for

any of the purposes listed above, ensure that its exposed end remains sealed to prevent grounding and damage to the display panel.

11.20. Display Panel Wiring Diagram

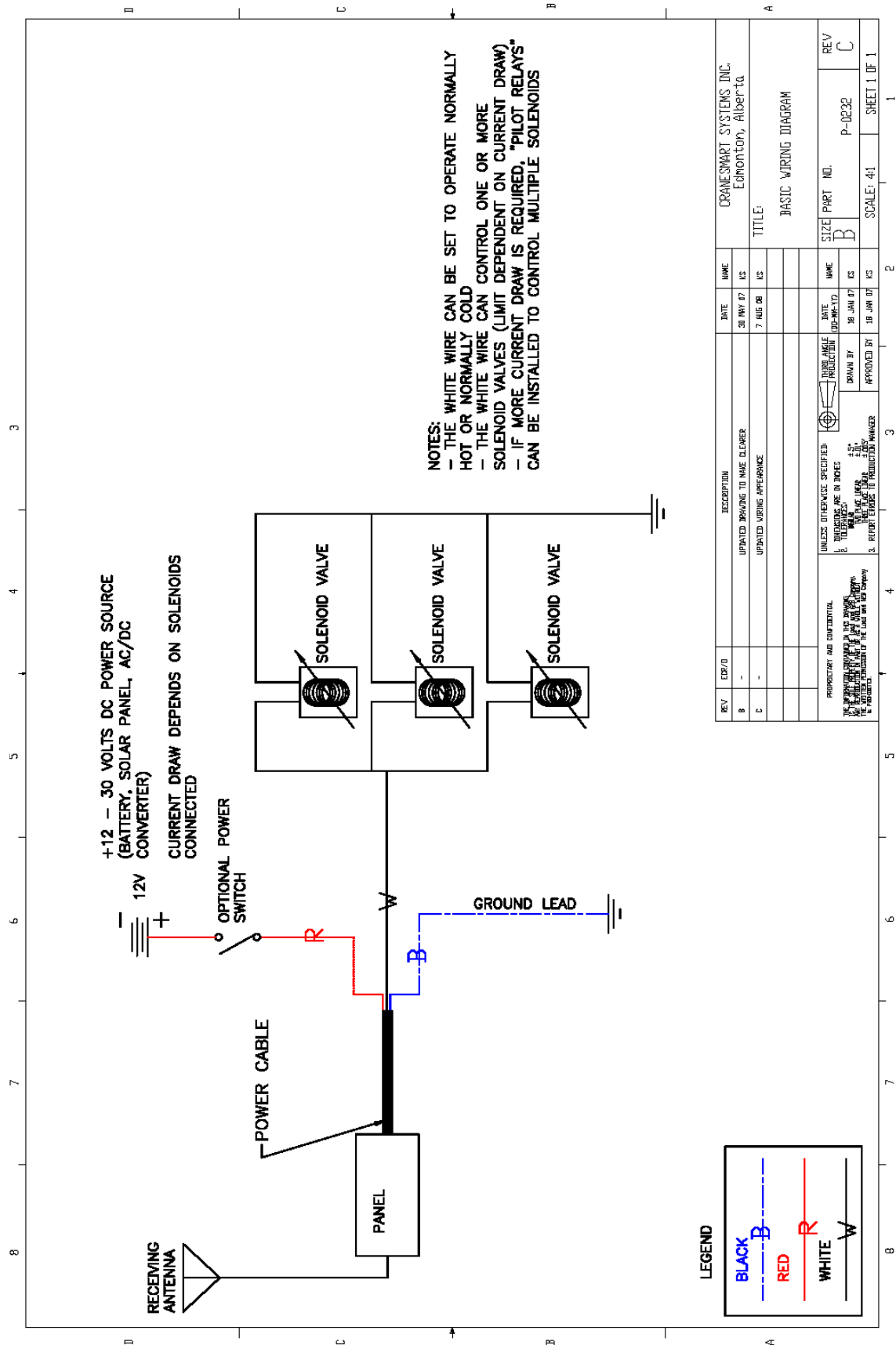

11.21. Power Converters

A power converter is needed to convert AC voltage to DC for the display panel. Cranesmart power converters change 110/220V AC to 12/24VDC, depending on the application. If a power converter is needed it will be discussed at the time of purchase.

11.22. Hazardous Area Options

In Class 1 Division 2 (C1D2) applications the Cranesmart system will wire identically to the basic wiring diagram – the only difference being that the panel has a pigtail with a red C1D2 connector on the end. The connector will mate with the corresponding C1D2 on a power cable or on the cable coming from the IMD. Use a set of tongue-in-groove pliers to fully tighten the connection, to ensure that the power cannot be accidentally loosened or disconnected by hand.

11.23. Integration Module (Digital) Installation

When used with the Digital Integration Module (IMD) the panel has the ability to control 4 separate outputs. These outputs can be set normally hot or normally cold. The alarms that control the outputs of the IMD are specified at the time of purchase.

The standard IMD comes supplied with the following cables:

- 4-pin alarm output cable
- 4-pin power cable, the ends of the cable are twisted together
- 2-pin ground
- 5-pin serial cable to connect the panel to the IMD.

1. Locate a position to mount the IMD where the operator can reach the wiring, if necessary.
2. Align the position mark and drill holes using the IMD mounting bracket holes as a guide.
3. Bolt the IMD in place.

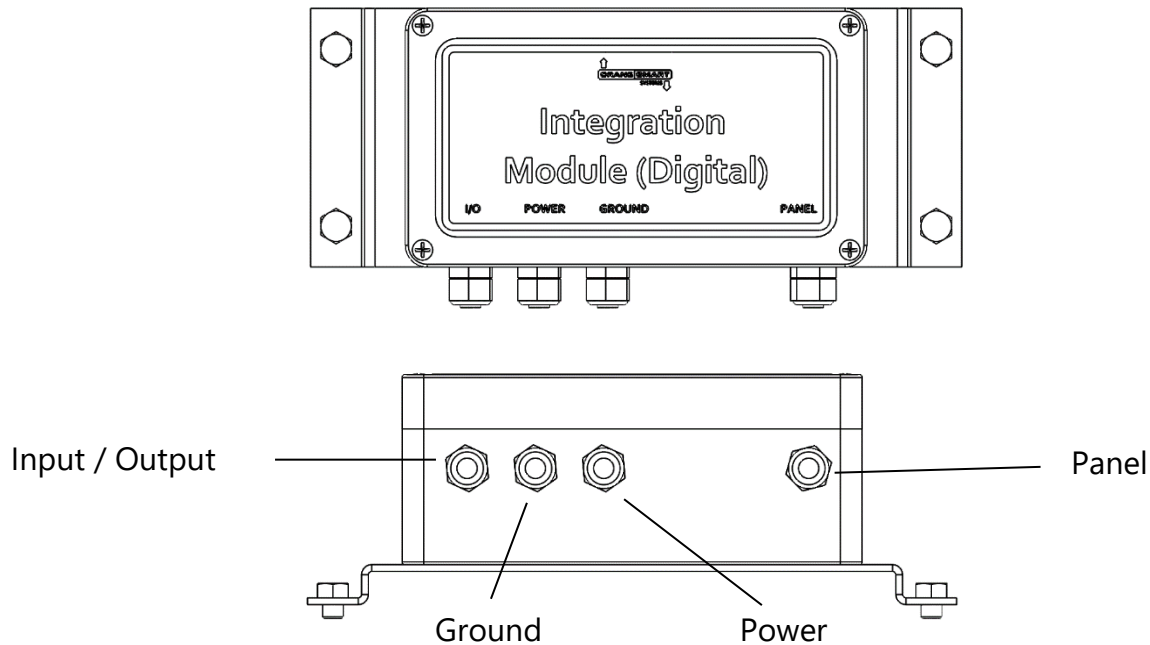

Wiring the IMD

1. Attach the black wire to electrical ground.
2. Attach the red wire to power 12-24Vdc.
3. Attach the serial cable from the IMD to the panel.
4. Use the custom insert as a guide to wire the alarm outputs.
5. Test to ensure that the outputs control the proper alarms.

Connecting the IMD to Power

1. Align the male and female ends of the connectors between the IMD and the power source.
2. Turn the threaded collar of the male of the power connection clockwise to hand-tighten the coupling.
3. Use a set of tongue-in-groove pliers to fully tighten the connection, to ensure that the power cannot be accidentally loosened or disconnected by hand.

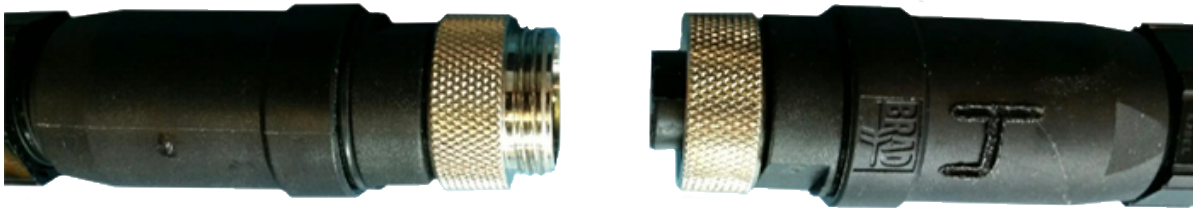

NOTES:

- ***The length of cable and the position of the panel will limit the mounting location of the IMD.***
- ***The plug is keyed to ensure a proper connection.***
- ***When a Cranesmart system is programmed for use with an IMD, the IMD must be present and working or the display will indicate an error. The IMD is crucial in this case, as power to the display panel is routed through it.***

11.24. IMD Wiring Diagram

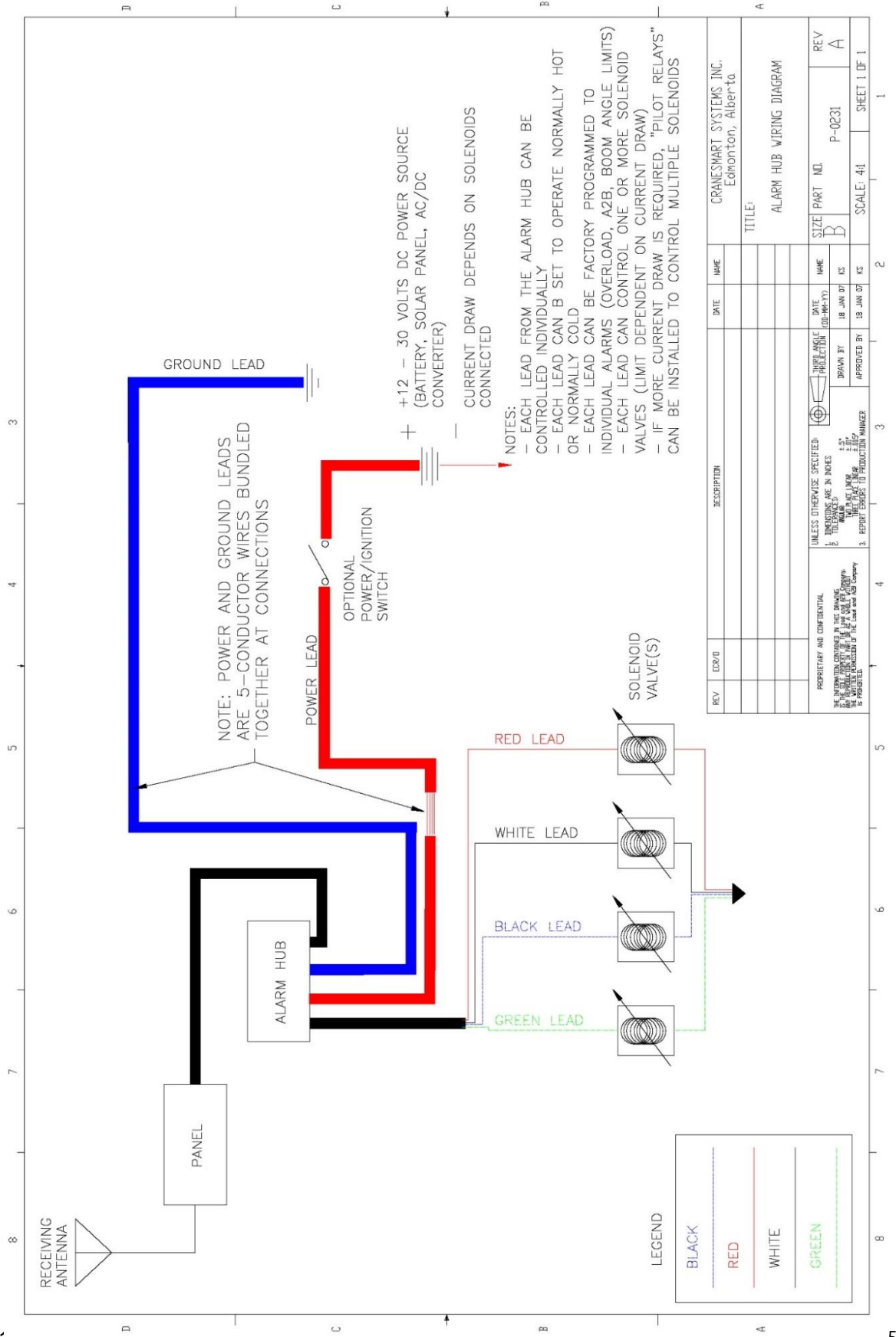

11.25. Antenna Installation

There are currently two types of antennas; installation and placement depend on the length and type of crane boom.

1. External Mount – for cranes with cabs.
2. Marine – for marine cranes with cabs.

NOTES:

- **Ensure that the lines of sight between the load cells, anti-2-block, switches, angle transducers and the antenna are not obstructed.**
- **Do not let the antenna touch glass or metal.**

Antenna Installation Type A (Inside Operator Cab)

When the display panel is mounted inside the cab of the crane, use the external magnetic mount antenna. This antenna will be included in the system packaging. Installation varies between cranes, but the following can be used as a guideline.

For optimum performance, the antenna should be installed horizontally as shown below but it will work in a vertical orientation also. To confirm the best position for the antenna, check the signal quality while moving it around (see the *Transducers* section of this manual).

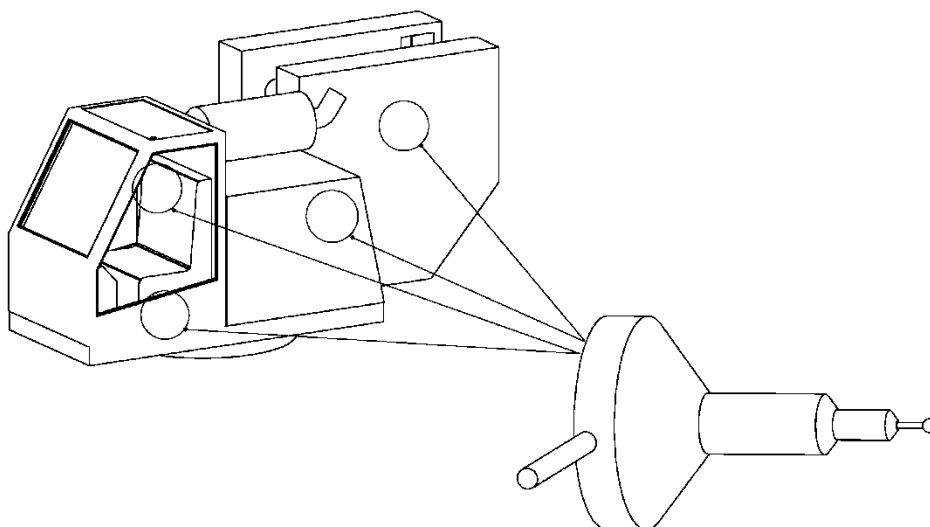

Antenna Installation Type B (Marine Installation)

When the Cranesmart system is used on a crane with a cab in a marine environment, use the external marine antenna included in the kit. Installation varies between cranes, but use the following can be used as a guideline.

For optimum performance, the antenna should be installed at a 45° angle as shown below. Determine the best position for the antenna by checking the signal quality on the signal display screen (see the *Transducers* section of this manual) while changing the angle, etc.

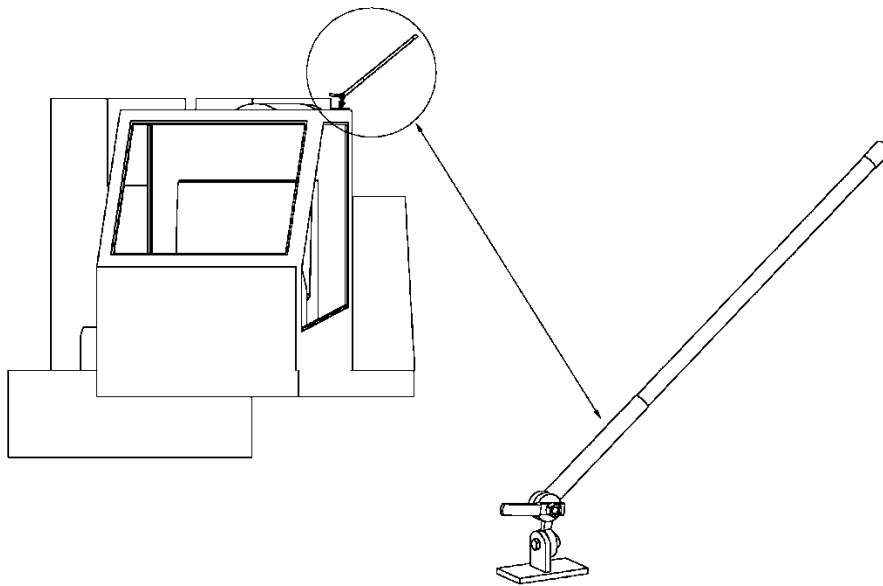

11.26. Shut-Off Bypass Plug

Not all systems require a shut-off bypass plug. The bypass plug is only required with systems that are using shut-off functions and only if those solenoids are normally hot (energized).

If the Cranesmart system was installed using the white output wire to control crane shut-offs (kick outs) and is overcome by damage or system malfunction, this wire can be bypassed using a bypass plug included with the kit. When this plug is installed as follows, it will allow the function kick outs to be re-energised.

1. Remove the power cable from the back of the display panel by twisting the coupling a half turn clockwise and pull it away from the panel.
2. Insert the bypass plug into the end of the power cable (lower illustration) – not the panel – and turn the plug a half turn clockwise.

NOTE: While this will restore crane functions, the Cranesmart system will no longer be monitoring crane functions.

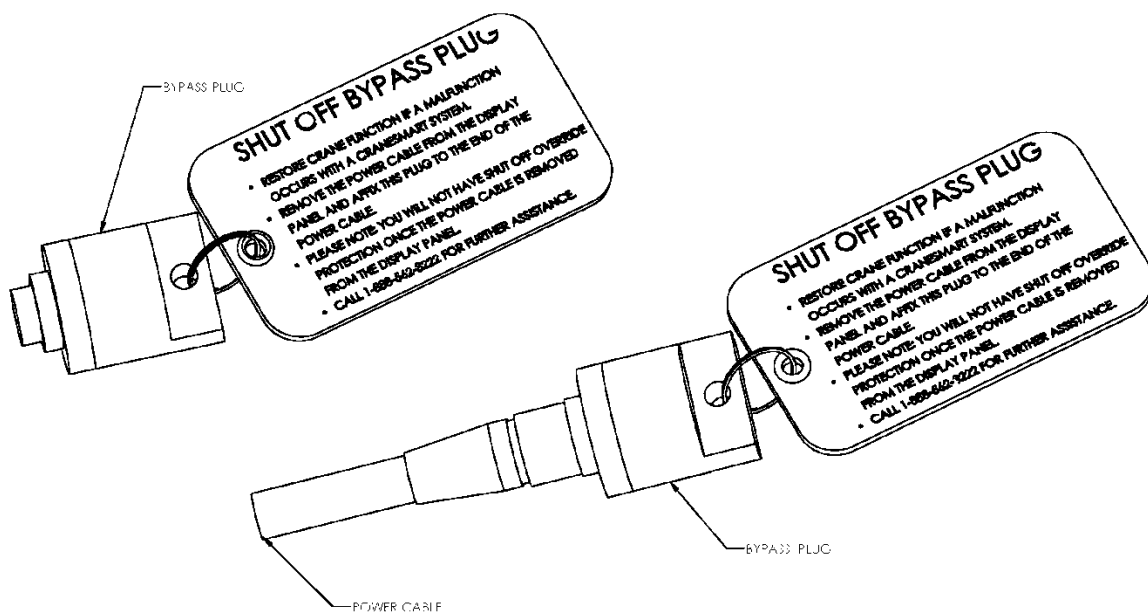

11.27. ASME B30.14 Excerpt (Power Lines)

The following excerpt from ASME B30.14 details the safety guidelines for operating side boom tractors near power lines.

ASME B30.14-2015

(15) Fig. 14-3.4.1-1 Danger Zone for Side Boom Tractors and Lifted Loads Operating Near Electrical Transmission Lines

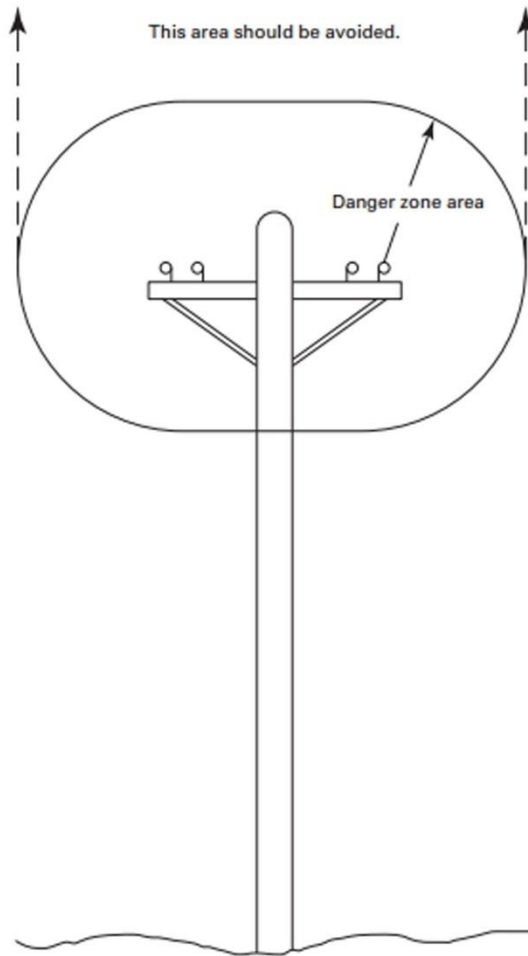

GENERAL NOTE: For minimum radial distance of danger zone, see para. 14-3.4.1.

(15) Table 14-3.4.1-1 Required Clearance for Normal Voltage in Operation Near High-Voltage Power Lines and Operation in Transit With No Load and Boom or Mast Lowered

Normal Voltage, kV (Phase to Phase)	Minimum Required Clearance, ft (m)
When Operating Near High Voltage Power Lines	
Up to 50	10 (3.05)
Over 50 to 200	15 (4.60)
Over 200 to 350	20 (6.10)
Over 350 to 500	25 (7.62)
Over 500 to 750	35 (10.67)
Over 750 to 1,000	45 (12.80)
While in Transit With No Load and Boom or Mast Lowered	
Up to 0.75	4 (1.22)
Over 0.75 to 50	6 (1.83)
Over 50 to 345	10 (3.05)
Over 345 to 750	16 (4.87)
Over 750 to 1,000	20 (6.10)

11.28. Occupational Safety and Health Administration 1926.1408 Excerpt (Power Lines)

The following excerpt from OSHA (1926.1408) details the safety guidelines for operating side boom tractors near power lines.

Federal Register / Vol. 75, No. 152 / Monday, August 9, 2010 / Rules and Regulations

§ 1926.1408 Power line safety (up to 350 kV)—equipment operations.

(a) *Hazard assessments and precautions inside the work zone.* Before beginning equipment operations, the employer must:

(1) *Identify the work zone by either:*

(i) Demarcating boundaries (such as with flags, or a device such as a range limit device or range control warning device) and prohibiting the operator from operating the equipment past those boundaries, or

(ii) Defining the work zone as the area 360 degrees around the equipment, up to the equipment's maximum working radius.

(2) Determine if any part of the equipment, load line or load (including rigging and lifting accessories), if operated up to the equipment's maximum working radius in the work zone, could get closer than 20 feet to a power line. If so, the employer must meet the requirements in Option (1), Option (2), or Option (3) of this section, as follows:

(i) *Option (1)—Deenergize and ground.* Confirm from the utility owner/operator that the power line has been deenergized and visibly grounded at the worksite.

(ii) *Option (2)—20 foot clearance.* Ensure that no part of the equipment, load line, or load (including rigging and lifting accessories), gets closer than 20 feet to the power line by implementing the measures specified in paragraph (b) of this section.

(iii) *Option (3)—Table A clearance.*

(A) Determine the line's voltage and the minimum approach distance permitted under Table A (see § 1926.1408).

(B) Determine if any part of the equipment, load line or load (including rigging and lifting accessories), while operating up to the equipment's maximum working radius in the work zone, could get closer than the minimum approach distance of the power line permitted under Table A (see § 1926.1408). If so, then the employer must follow the requirements in paragraph (b) of this section to ensure that no part of the equipment, load line, or load (including rigging and lifting accessories), gets closer to the line than the minimum approach distance.

(b) *Preventing encroachment/electrocution.* Where encroachment precautions are required under Option (2) or Option (3) of this section, all of the following requirements must be met:

(1) Conduct a planning meeting with the operator and the other workers who will be in the area of the equipment or load to review the location of the power line(s), and the steps that will be implemented to prevent encroachment/electrocution.

(2) If tag lines are used, they must be non-conductive.

(3) Erect and maintain an elevated warning line, barricade, or line of signs, in view of the operator, equipped with flags or similar high-visibility markings, at 20 feet from the power line (if using Option (2) of this section) or at the minimum approach distance under Table A (see § 1926.1408) (if using Option (3) of this section). If the operator is unable to see the elevated warning line, a dedicated spotter must be used as described in § 1926.1408(b)(4)(ii) in addition to implementing one of the measures described in §§ 1926.1408(b)(4)(i), (iii), (iv) and (v).

(4) Implement at least one of the following measures:

(i) A proximity alarm set to give the operator sufficient warning to prevent encroachment.

(ii) A dedicated spotter who is in continuous contact with the operator. Where this measure is selected, the dedicated spotter must:

(A) Be equipped with a visual aid to assist in identifying the minimum clearance distance. Examples of a visual aid include, but are not limited to: A clearly visible line painted on the ground; a clearly visible line of stanchions; a set of clearly visible line-of-sight landmarks (such as a fence post behind the dedicated spotter and a building corner ahead of the dedicated spotter).

(B) Be positioned to effectively gauge the clearance distance.

(C) Where necessary, use equipment that enables the dedicated spotter to communicate directly with the operator.

(D) Give timely information to the operator so that the required clearance distance can be maintained.

(iii) A device that automatically warns the operator when to stop movement, such as a range control warning device. Such a device must be set to give the operator sufficient warning to prevent encroachment.

(iv) A device that automatically limits range of movement, set to prevent encroachment.

(v) An insulating link/device, as defined in § 1926.1401, installed at a point between the end of the load line (or below) and the load.

(5) The requirements of paragraph (b)(4) of this section do not apply to work covered by subpart V of this part.

(c) *Voltage information.* Where Option (3) of this section is used, the utility owner/operator of the power lines must provide the requested voltage information within two working days of the employer's request.

(d) *Operations below power lines.*

(1) No part of the equipment, load line, or load (including rigging and lifting accessories) is allowed below a power line unless the employer has confirmed that the utility owner/operator has deenergized and (at the worksite) visibly grounded the power line, except where one of the exceptions in paragraph (d)(2) of this section applies.

(2) *Exceptions.* Paragraph (d)(1) of this section is inapplicable where the employer demonstrates that one of the following applies:

(i) The work is covered by subpart V of this part.

(ii) For equipment with non-extensible booms: The uppermost part of the equipment, with the boom at true vertical, would be more than 20 feet below the plane of the power line or more than the Table A of this section minimum clearance distance below the plane of the power line.

(iii) For equipment with articulating or extensible booms: The uppermost part of the equipment, with the boom in the fully extended position, at true vertical, would be more than 20 feet below the plane of the power line or more than the Table A of this section minimum clearance distance below the plane of the power line.

(iv) The employer demonstrates that compliance with paragraph (d)(1) of this section is infeasible and meets the requirements of § 1926.1410.

(e) *Power lines presumed energized.* The employer must assume that all power lines are energized unless the utility owner/operator confirms that the power line has been and continues to be deenergized and visibly grounded at the worksite.

(f) When working near transmitter/communication towers where the equipment is close enough for an electrical charge to be induced in the equipment or materials being handled, the transmitter must be deenergized or the following precautions must be taken:

(1) The equipment must be provided with an electrical ground.

(2) If tag lines are used, they must be non-conductive.

(g) *Training.*

(1) The employer must train each operator and crew member assigned to work with the equipment on all of the following:

(i) The procedures to be followed in the event of electrical contact with a power line. Such training must include:

(A) Information regarding the danger of electrocution from the operator simultaneously touching the equipment and the ground.

Federal Register / Vol. 75, No. 152 / Monday, August 9, 2010 / Rules and Regulations

(B) The importance to the operator's safety of remaining inside the cab except where there is an imminent danger of fire, explosion, or other emergency that necessitates leaving the cab.

(C) The safest means of evacuating from equipment that may be energized.

(D) The danger of the potentially energized zone around the equipment (step potential).

(E) The need for crew in the area to avoid approaching or touching the equipment and the load.

(F) Safe clearance distance from power lines.

(ii) Power lines are presumed to be energized unless the utility owner/operator confirms that the power line has been and continues to be deenergized and visibly grounded at the worksite.

(iii) Power lines are presumed to be uninsulated unless the utility owner/operator or a registered engineer who is a qualified person with respect to electrical power transmission and distribution confirms that a line is insulated.

(iv) The limitations of an insulating link/device, proximity alarm, and range control (and similar) device, if used.

(v) The procedures to be followed to properly ground equipment and the limitations of grounding.

(2) Employees working as dedicated spotters must be trained to enable them to effectively perform their task, including training on the applicable requirements of this section.

(3) Training under this section must be administered in accordance with § 1926.1430(g).

(h) Devices originally designed by the manufacturer for use as: A safety device (see § 1926.1415), operational aid, or a means to prevent power line contact or electrocution, when used to comply with this section, must meet the manufacturer's procedures for use and conditions of use.

TABLE A—MINIMUM CLEARANCE DISTANCES

Voltage (nominal, kV, alternating current)	Minimum clearance distance (feet)
up to 50	10
over 50 to 200	15
over 200 to 350	20
over 350 to 500	25
over 500 to 750	35
over 750 to 1,000	45
over 1,000	(as established by the utility owner/operator or registered professional engineer who is a qualified person with respect to electrical power transmission and distribution).

Note: The value that follows "to" is up to and includes that value. For example, over 50 to 200 means up to and including 200kV.